

BEST MANAGEMENT PRACTICES
MANUAL FOR UTILITY
MAINTENANCE IN AND ADJACENT
TO WETLANDS AND WATERBODIES
IN NEW HAMPSHIRE

INTERIM
JANUARY 2010

NEW HAMPSHIRE DEPARTMENT OF
RESOURCES AND ECONOMIC DEVELOPMENT

Interim Manual Approval Letter by Rene Pelletier

Table of Contents

Page

1. Introduction	1
1.1. Purpose	1
1.2. Policy	1
1.3. Scope	1
2. Applicable Regulations	2
2.1. Wetland Regulations	2
3. Project Planning	2
3.1. Avoidance and Minimization	3
3.2. Meetings	3
3.3. Timing of Work	3
3.4. Alternate Access	4
4. Resource Identification	4
4.1. Wetland Types	4
4.2. Forested Wetlands	5
4.3. Scrub-Shrub Wetlands	6
4.4. Emergent Wetlands	6
4.5. Streams	7
4.6. Vernal Pools	7
4.7. Wetland Buffers	8
4.8. Wetland Vegetation	8
4.9. Hydric Soils	14
4.10. Wetland Hydrology	16
4.11. How to Identify Wetlands	17
4.12. Recognition of Invasive Species	18
5. Best Management Practices	22
5.1. Introduction	22
5.2. Applying Best Management Practices	22
5.3. General Management Practices	22
5.4. Utilization of Access Ways for Maintenance	23
5.5. Best Management Practices for Access	24
5.6. Operating near Wetlands and Waterbodies	24
5.7. Crossing Wetlands	24
5.8. Stream Crossings	27
5.9. Invasive Species	28
5.10. Restoration of Disturbed Areas	29
5.11. Inspection and Maintenance	
5.12. Best Management Practices	30
Appendices	
Appendix A – Glossary	61
Appendix B – References	66

Best Management Practices Manual for Utility Maintenance in and Adjacent to Wetlands and Waterbodies in New Hampshire

1. INTRODUCTION

1.1.Purpose

Utility service providers (including but not limited to electric, gas etc) are responsible for providing safe and reliable energy and other services to their customers and are required under certain federal regulations to maintain electrical and other right of way corridors. These corridors often cross natural resource areas, such as wetlands and waterbodies that are regulated by the NH Department of Environmental Services (NHDES). The purpose of this manual is to provide guidance to electric, gas and other service providers and their contractors in order to identify appropriate means and methods for vegetation management and maintaining utility assets in or within the vicinity of jurisdictional wetlands.

1.2.Policy

In accordance with basic tenets of environmental stewardship, and in accordance with state and federal regulations, all work performed by utility service providers and their contractors within utility rights-of-ways (ROWs) shall use environmentally sound best management practices (BMPs) to minimize or eliminate potential adverse environmental impacts.

1.3.Scope

This manual will allow utility service providers to identify wetlands, work practices, limitations and activities that are relevant to work in and adjacent to wetlands and waterbodies. This manual also identifies work that is considered outside the scope of the manual and indicates instances where separate reporting/application procedures are required.

These BMPs primarily address the issue of disturbance of soil, water, and vegetation that may occur during vegetation clearing and maintenance (both routine and emergency) within utility ROWs. This manual addresses work areas, maintenance of access ways, crossings of wetlands and waterbodies, and work in the vicinity of wetlands and waterbodies that are necessary for the routine maintenance of utility corridors and utility structures.

This manual is not intended to address the following activities:

- Establishing new access roads
- Installation of permanent crossings of streams and wetlands
- New construction of utility assets
- Herbicide or Pesticide application for vegetation management

Other important issues such as oil spill procedures, handling of contaminated soils, and work safety rules shall be addressed within other documents and procedures issued by the utility service provider.

2. Applicable Regulations

2.1. Wetlands Regulations

Federal Regulations — Federal wetland regulations are covered under section 404 of the Clean Water Act (CWA) and are regulated by the U S Army Corps of Engineers (USACE). For the purpose of this manual, the activities identified as routine maintenance are covered under a State Programmatic General Permit (SPGP), which is an agreement between the USACE and the NHDES that allows these activities to be regulated by the State.

State Regulations — the NH DES Wetlands Bureau administers the state wetland regulations. These regulations (Env-Wt 100-800) require a permit for all impacts (disturbance, fill, and dredge) whether temporary or permanent. The guidance within this document is intended to be used as part of compliance under *UTILITY MAINTENANCE NOTIFICATION FORM*. Any activity outside of those identified may require a separate permit.

3. Project Planning

Regardless of whether a specific permit is needed for the work, construction and maintenance projects must follow clear and enforceable environmental performance standards, which is why these BMPs have been compiled. This Utility Maintenance Notification process does not apply to new construction but is intended for routine maintenance and vegetation management.

3.1 Avoidance and Minimization

Measures should always be taken to avoid impacts to wetlands, waterways, and sensitive areas. If avoidance is not possible, then measures should be taken to minimize the extent of impacts. Alternate access routes or staging areas should always be considered. Below is a list of methods that should be considered where impacts are unavoidable:

- Minimize the width of typical access roads through wetlands (wider than 16 feet is generally not necessary);
- Use low-impact vehicles and/or vehicles with low ground pressure when driving through wetlands.
- Coordinate the timing of work to cause the least impacts (e.g. during the regulatory low-flow period (July 1 – October 1), when water/ground is frozen, after the spring songbird nesting season);
- Use swamp, timber, or similar mats in wetlands to minimize soil disturbance and rutting when work needs to occur during non-frozen ground conditions; and
- Conduct work manually, whenever possible.

3.2 Meetings

Pre-maintenance meetings are typically held prior to the commencement of all work to appoint responsible parties, discuss timing of work, and further consider options to avoid and/or minimize impacts to sensitive areas. These meetings can occur on or off-site and should include all the willing and available stakeholders (i.e., utility employees, contractors, consultants, inspectors, and/or monitors, and regulatory personnel). A brief **Pre-job briefing** would suffice for smaller maintenance projects.

Pre-job briefings are daily or otherwise routine meetings that are conducted on-site with the work crew throughout the duration of the work. These meetings are a way of keeping everyone up to date, confirming there is consensus on work methods and responsibilities, and ensuring that tasks are being fulfilled with as little impact to the environment as possible.

3.3 Timing of Work

- **Work during frozen conditions.** Activities conducted once wetland areas are frozen can minimize rutting and other impacts to the surrounding environment. Work during this time also generally reduces disturbance of aquatic and terrestrial wildlife movement by avoiding sensitive breeding and nesting seasons.

- **Work during the “low flow” period.** The U.S. Army Corps of Engineers regulatory low-flow period is designated as July 1 through October 1. Conducting work during the low-flow period can reduce impacts to surface water and generally avoids spawning and breeding seasons of aquatic organisms.

3.4 Alternate Access

- **Manual Access.** In some cases such as for smaller projects, work areas can be accessed manually – on foot through terrestrial areas, and by boat through open water or ponded areas. Smaller projects, such as repair of individual structures, or parts of structures, that do not categorically require the use of heavy machinery, should be accessed manually to the greatest extent practicable.
- **Use of overhead/aerial access.** Using overhead or aerial equipment can be expensive and is not always feasible, but it may be appropriate in some situations in order to get vehicles and other equipment to a site that otherwise may be very difficult to access. The use of overhead and/or aerial equipment may be beneficial for work in areas where larger water bodies, deep crevices, or mountainous areas hinder ground access.

4. Resource Identification

4.1 Wetland Types

Wetlands are defined as those areas that are inundated or saturated at a frequency and duration sufficient to support, and that under normal circumstances do support, a prevalence of vegetation typically adapted for life in saturated soil conditions. Wetlands generally include swamps, marshes, bogs and similar areas.

Wetlands tend to be located in depressions, at the toe of slopes or in other areas where one might envision water collecting. Wetlands in New Hampshire are identified using a three-parameter approach of **1)** hydrophytic (wetland) vegetation, **2)** hydric soils and **3)** wetland hydrology. With the exception of heavily disturbed sites, all three parameters are required for an area to be considered a jurisdictional wetland.



Figure 1: Shallow Emergent Marsh Wetland System

If an area is heavily disturbed all three parameters may not be present and identification of all three would not be required for the area to be considered a wetland. Examples of this would be the complete removal of vegetation or grading of soils within the wetlands. Current practices of utility ROW Vegetation Management do not regularly fall within this guideline because the vegetation is only cut and most of the species re-generate from stump sprouts or existing root stock and can still be used in wetland identification.

4.2 Forested Wetlands

Forested Wetlands in New Hampshire are typically drier wetlands with standing water during periods of high water (early spring through mid summer) and during large rain events. Red Maple and Hemlock are key identifiers of these wetlands. These wetlands tend to have pit and mound topography and the trees appear to be standing up on their roots.



Figure 2: Forested Wetland System

4.3 Scrub-Shrub Wetlands

Scrub-shrub wetlands tend to be wetter than forested wetlands and may have standing water in places at all times except for the driest time of the year, for example, in late summer.



Figure 3: Scrub-Shrub Wetland System

4.4 Emergent Wetlands

Emergent wetlands such as marshes and wet meadows, can vary by type, however, marshes usually do not contain a significant amount of woody vegetation.

4.4.1 Marshes

Marshes are areas that are distinguished by the absence of trees and shrubs. Marshes are considered surface water as well as wetlands under state law. These areas are typically dominated by soft-stemmed species such as grasses, cattails, sedges



Figure 4: Emergent Wetland System

and rushes and usually have a water table at or above the ground elevation for most of the year.

4.4.2 Wet Meadows

Wet Meadows are areas dominated by non-woody species. These areas are typically saturated during the year but usually not flooded. These areas may exist due to frequent mowing to keep vegetation down. Wet meadow vegetation is varied and can include such common species as tussock sedge, rushes, grasses like blue joint and reed canary grass, and flowering herbaceous plants including Joe-Pye-weed, goldenrod, aster, and many others.



Figure 5: Wet Meadow Wetland System

4.5 Streams

Streams in New Hampshire are defined as:

Perennial – A stream that flows for the majority of the year.

Intermittent – A stream that flows for sufficient time to develop and maintain a defined channel, but may not flow during dry portions of the year.

Because work takes place year round, it is more important to have guidelines based on the methods appropriate for crossing (See Section 5.8 of this manual).

4.6 Vernal Pools

Vernal Pools are shallow depressions that pond water in the spring but tends to dry up by mid summer. These areas do not have permanent above ground outlets. Vernal pools usually lack vegetation in the middle of them. (See NH Code of Administrative Rules PART Env – Wt 301.01 (f))

These areas are important breeding grounds for some of New Hampshire's rarest amphibians such as spotted salamanders and wood frogs. Because they dry up in the summer and typically do not have an above ground outlet, they do not support fish.

These areas have been shown to only function with a buffer of trees around them. The trees provide shading that keeps the water temperature cooler and provides a longer ponding time that supports amphibian breeding. The following characteristics can be used to identify potential vernal pool habitats:

- Ponded water with no outlet
- Dark or gray stained leaves in a shallow depression that is dry in the summer
- A depression with no vegetation that appears to pond 1-3 feet of water



Figure 6: Stream Wetland System



Figure 7: Vernal Pool Wetland System

4.7. Wetland Buffers

Wetland buffers are vegetated areas adjacent to wetlands that provide important protections and enhancements to the wetlands. These areas can provide filters to treat polluted water from human sources such as roads and lawns. They also provide an important wildlife habitat adjacent to wetland areas. When possible, the integrity of a wetland buffer should be maintained during utility ROW maintenance activities. Make sure all appropriate local approvals have been obtained from the town, as needed, to work in buffers.

4.8. Wetland Vegetation

Hydrophytes (plants adapted for life in water or saturated soils) are one of the criteria for identifying wetlands. The US Fish and Wildlife Service (US F&WS) has published the *National List of Plant Species that Occur in Wetlands – Northeast Region* which is a list of plants that ranks the plants according to the frequency of occurrence within wetlands. These classifications are as follows: obligate wetland (OBL), facultative wetland (FACW), facultative (FAC), facultative upland (FACU) and upland (UPL). Wetlands by definition must have more than 50% of the plants being OBL, FACW or FAC.

Wetland Plants	Comment
Obligate (OBL)	Occurs almost always (estimated probability 99%) under natural conditions in wetlands.
Facultative (FACW)	Usually occurs in wetlands (estimated probability 67%-99%), but occasionally found in non-wetlands.
Facultative (FAC)	Equally likely to occur in wetlands or non-wetlands (estimated probability 34%-66%).
Facultative (FACU)	Usually occurs in non-wetlands (estimated probability 67%-99%), but occasionally found in wetlands (estimated probability 1%-33%).
Upland (UPL)	Occurs in wetlands in another region but occurs almost always (estimated probability 99%) under natural conditions in non-wetlands in the regions specified.



Cattail – Obligate wetland herb. These plants are readily identifiable with their long grass like look. They typically will grow in standing water and at the edge of ponds.



Red Maple – Facultative tree, grows in either wetland or upland but is considered a wetland indicator species. The stems of this tree give it its name with their red hue. The leaves are opposite with usually 3 lobes that have very serrated edges. Red maples grow either singly or in clumps.

Speckled Alder – Facultative Wetland shrub, typically grows in wetlands. This shrub grows to 20 feet and has small brown catkins (seed pods) that persist through the winter.



Sensitive Fern – Facultative Wetland herb. Typically found in seep wetlands. The leaf of this plant is very distinct and the seed head usually persist through the winter and stick up above the snow after the rest of the plant is gone.



Sphagnum Moss – While not a true plant, this moss is a good indicator of wetlands. It usually forms a blanket in areas where water stands for some portion of the year.



Highbush Blueberry – Facultative wetland, grows in either wetland or upland but is considered a wetland indicator species. The characteristic blueberries show up in mid summer and are a wildlife favorite. These multi-stemmed shrubs tend to grow to about 8 feet and have scaly bark.



Gray Birch – Facultative tree, grows in either wetland or upland but is considered a wetland indicator species. This small growing birch has dirty white bark as it grows older and never reaches taller than 20-25 feet. The trees even when old are often weak and it is not uncommon to see them bent over from damages cause by ice storms. These differ from white or paper birch by having more triangular shaped leaves and often growing in clumps as opposed to singularly in paper birch. Also, the bark of this tree does not naturally peel like the paper birch.

Silky Dogwood – Facultative shrub, grows in either wetland or upland but is considered a wetland indicator species. It tends to grow in thick clumps. Dogwood leaves are unique in that they are opposite with smooth edges and leaf veins that almost look parallel.





Elderberry– Facultative Wetland shrub. This shrub with compound leaves often looks like it has a lot of dead branches. It flowers in early to mid summer with clumps of white flowers at the ends of branches. It fruits in the summer and the berries persist to the fall.

Tussock Sedge – Obligate Wetland herb – This common sedge species almost always grows in wetlands. It is characterized by growing in clumps and is usually surrounded by standing water for some period of time.



The following list includes some common plants found in different types of NH wetlands:

Obligate Wetland plants (OBL)
99% of time in wetland

Tree

Atlantic White Cedar

Shrub

Buttonbush

Herbs

Tussock Sedge

Royal Fern

Blue Flag Iris

Pickeralweed

Marsh Smartweed

Skunk Cabbage

Facultative Wet and Facultative plants (FACW & FAC)
67% – 99% and 34 % - 66% of the time in wetlands respectively

Trees

Red Maple

Gray Birch

Yellow Birch

American Elm

Shrubs

Speckled Alder

Highbush Blueberry

Meadowsweet

Winterberry

Silky Dogwood

Northern Arrow-wood

Herbs

Cinnamon Fern

Sensitive Fern

New England Aster

Woolgrass

Purple Loosestrife*

Reed Canary Grass

Common Reed (Phragmites) *

Upland Vegetation (UPL)
1% of the time in wetlands

Trees

White Pine

Red Oak

American Beech

Sugar Maple

Shrubs

Striped Maple

Maple-leaved Viburnum

Huckleberry

Herbs

Bracken Fern

Tree Clubmoss

Partridge-berry

* Invasive Species

4.9. Hydric Soils

A Hydric (wetland) soil is a soil that has developed under saturated conditions. The saturated conditions are lengthy enough to produce an anaerobic (lack of oxygen) environment within the soil. The saturation comes from the same water that drives the wetland development. Hydric soils are usually identified by some of the following characteristics:

- A very dark or thick topsoil layer
- A high amount of organic matter in the topsoil. (Can be tested by squeezing a clump of soil. If the soil flows between the fingers then it is organic)
- Blotchy colors (mottles or redoximorphic features) at or near the surface
- A gray colored layer within 20 inches of the surface



A dark surface layer indicating a possible wetland soil.

FROM: USDA-NRCS WETLAND SCIENCE INSTITUTE



An example of blotches indicating a fluctuating (seasonal) water table.

4. **FROM :USDA-NRCS WETLAND SCIENCE INSTITUTE**

A soil profile with a reduced (gray) matrix. The orange blotches also indicate a fluctuating water table.



**FROM USDA-NRCS WETLAND
SCIENCE INSTITUTE**

4.10. Wetland Hydrology

The wetland hydrology, the presence or absence of water, is the driving force behind any wetland. Without the presence of water for a minimum of two weeks during the growing season, the soils would not become anaerobic and the wetland vegetation would not be as strongly represented.

Indications of hydrology are fairly easy to identify in the spring when the water table is at its highest and most wetlands are ponded or saturated enough for water to be apparent. However, as the spring turns into summer, the water table drops and it is necessary to focus on other indicators for confirmation that the area is a wetland. The following characteristics may be observed:

- Drainage patterns, or scoured channels representing intermittent streams
- Water or silt stained plant stems
- Water stained (gray or black in color) or silt covered leaves
- Lines of organic debris, such as leaf litter, on tree and shrub stems above soil surface
- Swollen bases of tree trunks or exposed plant roots which is an adaptation to wet soils
- Soils showing observable features of being saturated or flooded for long periods of time
- Sphagnum moss on the surface

4.11. How to Identify Wetlands

Identifying wetlands is usually done by the USACE 1987 method; however, with appropriate background and training, areas that are wetlands or possible wetlands can be identified. The following guidelines will be used in determining if an area is a wetland:

- ✓ **Does the area have standing water?** During most times of the year, if there is standing water, the area is most likely a wetland. It is important to note however, that in the spring when water tables are at their highest, many areas that are not wetlands may have standing water. These areas are still of concern because of the high water table. Any excessive activity in these areas may cause rutting and soil disturbance that can lead to erosion and other issues.
- ✓ **Is the area void of any woody plants?** Typically areas that don't have woody plants, such as shrubs and trees are marsh and wet meadow wetlands. These areas also usually have standing water except in the drier times of the year.
- ✓ **Is there a defined channel?** A defined channel is one of the criteria that the NHDES uses to identify streams, whether they are perennial streams or small intermittent streams.
- ✓ **Do plants typical in wetlands dominate the area?** Knowing a few key species of plants will help in determining if an area is a possible wetland. Areas dominated by shrub species, such as speckled alder, willow, high bush blueberry and meadowsweet is typical of wetlands. Also areas with tree species such as red maple or large fern species such as cinnamon fern are indicators of a wetland.
- ✓ **Does the area look like it ponds water during wetter times of the year?** While working in area during dryer summer months it may seem more difficult to determine if an area is a wetland but the ground will provide clues. Areas with gray or black stained leaves on the ground mean that the area was ponded. Look for pit and mound micro-topography where trees and shrubs are growing on the mounds. Carefully investigate low lying areas where it looks like water would collect.

4.12. Recognition of Invasive Species

Wetlands found on utility ROWs in New Hampshire may contain non-native plants (invasive species) that are easily spread and compete with native vegetation.

Within the confines of this BMP manual the two species of concern are purple loosestrife (*Lythrum salicaria*) and common reed (*Phragmites australis*). Extreme care should be used whenever an activity occurs in or adjacent to areas where these plants are found. If at all possible, machinery should be kept out of areas dominated by these plants. Where vehicles must enter areas with these plants, refer to section 5 to prevent further spread of these invasive plants.

4.12.1. Purple Loosestrife (*Lythrum salicaria*)

Identification

Purple loosestrife is an herbaceous, perennial plant, growing 2-6 feet tall, forming large colonies that can originate from a single plant. The stems are reddish-purple and can appear square in cross section. The leaves are lanceolate, 1-4 inches long and 0.5-1 inch wide. The leaves are opposite one another or in whorls of three. Spikes of purple flowers are easily recognized in late July into August. Millions of seeds per plant are dispersed largely by drift in moving water and over long distances by seeds imbedded in mud on water birds, trucks, off-road vehicles, and matting systems.



Habitat



Purple loosestrife will set seed quickly and grow at a faster rate than native species, so as to choke them out and slowly eradicate them from the ecosystem, as they out compete for light, space and nutrients. This can damage valuable wildlife habitat as well as streams and rivers.

Purple loosestrife prefers to grow in open emergent wetlands and is easily introduced when the soil is disturbed. Once established, it can survive with 50% of full sun, but declines in vigor at lower light levels.

The plants grow on a wide range of substrates, but are more successful on slightly acid or neutral soils.

The impact of purple loosestrife on native vegetation has been disastrous, with more than 50% of the biomass of some wetland communities displaced. Impacts on wildlife have not been well studied, but indicate serious reductions in waterfowl and aquatic mammals. With the continued expansion of purple loosestrife, several declining species of vertebrates are threatened with further degradation of their breeding habitats.

Purple Loosestrife in winter:



4.12.2. Common Reed
(*Phragmites australis*)

Identification

Common reed is a colonial grass species with woody hollow stems that can grow up to 6 – 12 feet in height. Leaves are flat and smooth, often 6 – 18 inches long and 1/2 – 2 inches wide. Flowers develop by mid-



summer and are arranged in tawny spikelets with many tufts of silky hair. Seed set is highly variable and occurs through fall and winter and may be important in colonization of new areas. Germination occurs in spring on exposed moist soils. Vegetative spread by below ground rhizomes can result in dense clumps with up to 200 stems/m².

Habitat

Common reed is a tall grass that inhabits wet areas such as brackish and freshwater marshes, riverbanks, lakeshores, ditches and dredge spoil areas. Native and introduced forms of *Phragmites* occur in the United States. Researchers believe that introduced European forms are the aggressive invasives that have replaced much of our native reed. Common reed threatens by displacing native plants and forming monocultures in otherwise biologically diverse natural wetlands. It spreads by seed and strong vegetative rhizome growth and is very difficult to control once established. Disturbed areas are particularly prone to invasion by this plant.

Phragmites australis invasion alters the structure and function of diverse marsh ecosystems by changing nutrient cycles and hydrological conditions. Dense *Phragmites* stands in North America decrease native biodiversity and quality of wetland habitat, particularly for migrating waders and waterfowl species.

Quick Identification

- The plant is a tall grass growing in monoculture clumps
- The grass is very tall at maturity often ranging from 6 to 12 feet in height. The flowers bloom between mid-July and September
- The leaf blade is flat; smooth; 1/2 to 2 inches wide; and 6 to 18 inches long
- The seed head is open and shaped like a multi-branched feather. It is purplish or tawny and flag like appearance after seed shatter
- Common reed is readily identified by its height. It is the tallest grass in the northeast

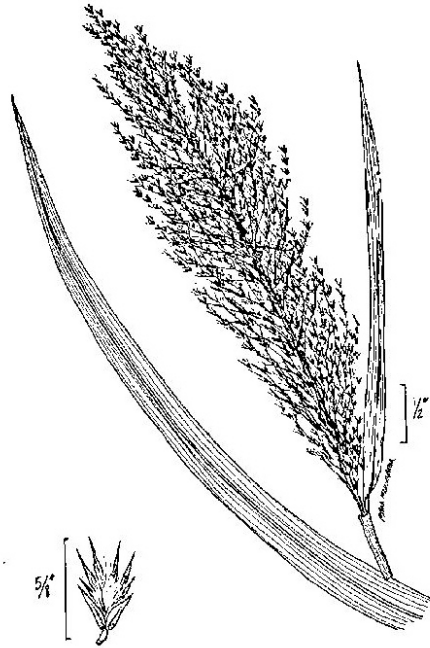

COURTESY USDA-NRCS PLANTS DATABASE

5 Best Management Practices (BMPs)

5.1 Introduction

The following is a list of BMPs that shall be appropriately applied when performing all maintenance and vegetation management related to keeping the utility assets in compliance with utility industry standards. Regardless of whether a specific permit is needed for the work, construction and maintenance projects must follow clear and enforceable environmental performance standards, which is why these BMPs have been compiled. These methods will ensure the utility service provider and their subcontractors meet the conditions of the Utilities Maintenance Notification process.

Maintenance activities covered under this section include, but are not limited to:

- Cyclical and Emergency Vegetation Management
- Line Maintenance and Repair
- Inspection Activities
- Ground Line Treatment Programs

5.2. Applying Best Management Practices

The best scenario is to do work under the following conditions:

- The ground is frozen or sufficiently dry to avoid making ruts.
- Existing access ways where no additional rutting will occur.
- The roots of the vegetation are not disturbed.
- Small streams that can be straddled by tracked machines with no disturbance to either the banks or the bed of the stream.

Where there is potential for erosion to cause sedimentation the BMPs in Section 5 shall be utilized.

5.3. General Management Practices

Several steps will be taken prior to the beginning of any maintenance activity in order to avoid and minimize any unnecessary impacts to wetlands. These measures include:

- Avoidance – The first thing that will be considered is if impacting this wetland can be avoided. This may not be possible for a number of reasons including no access, poor seasonal conditions, property rights constraints and equipment requirements/constraints.
- Minimizing disturbed area — Limit the area of tracking of vehicles. Use one pass in and out when possible.
- Preserving low growing native vegetation — in areas where the vegetation is

dominated by low-growing native wetlands species, selectively cut targeted tree and shrub species.

- Maintain equipment in good operating order – Inspect for leaks on a daily basis. Fuel in areas where an accidental spill will not have the chance to reach a wetland. Utility service providers and their subcontractors are required to carry spill kits.
- Pre-job Briefing - Utility service providers and their subcontractors will conduct a pre-job briefing prior to commencement of any project. This discussion will include what is known of the ROW and potential problem areas and each utility shall develop and maintain a checklist. Where it is known that wetlands will be crossed, the discussion shall include expected methods for crossing and how to report any problems.
- Vegetation Management – In areas dominated by invasive plants such as Phragmites and purple loosestrife, avoid the use of mechanical equipment and perform manual cutting of targeted species. If mechanical cutting is required, follow the invasive species control section of this manual (see section 5.9.2).
- Access - Equipment and general traffic to and from a work site on a ROW must use the established access way when one exists and is readily passable.
- Communications - In the event that a situation arises that is outside the scope of this manual, the field representative shall contact utility service provider immediately.
- Fueling, Storage of Fuel and Dust Control Materials - Fuel, oil, hydraulic fluids and dust control substances shall not be stored within 100' of wetlands or waterbodies. Refueling of over the road vehicles shall not occur within 100' of wetlands or waterbodies. Heavy construction equipment may be refueled on the work site only outside wetlands and no closer than 100 feet from watercourses. A fuel spill control plan and equipment shall be provided on the site and appropriate cleanup and reporting procedures shall be followed.
- Waste Products - Waste products and misc debris resulting from maintenance activities require special attention to prevent harm to people, wildlife, water resources, or vegetation. At minimum electric service providers and their contractors will take all required precautions to remove and manage these wastes in accordance with the appropriate rules and regulations.

5.4. Utilization of Access Ways for Maintenance

Access ways are used on ROWs where activities involving maintenance occur at a regular interval and good access is essential. The construction of new and permanent access ways for any maintenance project is beyond the scope of this BMP manual and would require separate and additional permitting.

Equipment and general traffic to reach a particular portion of ROW must use the established access way whenever possible. *Established access ways have often been developed to prevent degradation of the utility corridor, and must be used, and maintained in accordance with the measures outlined*

within these BMPs. Implementing duplicate or new access ways should be avoided to the fullest extent possible.

5.5. Best Management Practices for Access Ways

The following is a list of available BMPs that can be used in conjunction with existing access ways.

- Stabilization (BMP #9)
- Silt Fence and other Perimeter Controls (BMPs # 1,2 & 3)
- Surface Water Diversions (BMPs #12 & 13)
- Temporary Crossings of Wetlands on Existing Access Way
 - Corduroy (BMP #7)
 - Mats (BMP #6)
 - Other Methods (BMP #8)
- Appropriate Mulching Material (BMP #5)
- Seed
 - Temporary & Permanent (BMP #4)

These measures are located in Appendix A.

5.6. Operating Adjacent to Wetlands and Waterbodies

Work adjacent to wetlands and waterbodies, but not necessarily in wetlands and waterbodies, can present potential environmental impacts. Care must be taken when working in these areas.

To minimize erosion potential, all low growing varieties of vegetation adjacent to wetlands must be preserved to the fullest extent possible. Stumps and rocks must not be removed, and there must be no excavations, fills or grading done adjacent to wetlands.

Excess sediment disposal from any activity within the controlled area must be removed and placed at an upland site, and suitably contained to prevent erosion and/or transport to a wetland or watercourse.

Equipment shall not be parked adjacent to wetlands or watercourses. Equipment operation adjacent to wetlands and watercourses shall be limited. No fueling will occur in wetlands.

If you are working in an upland site that presents a sediment and/or erosion problem to a nearby wetland or waterbody, please refer to BMP#3 for additional work requirements.

5.7. Crossing Wetlands

Because ROWs are linear and require year round routine maintenance, crossing of wetlands is often unavoidable. These utility maintenance activities are essential good management practices for providing reliable service.

In deciding if, where, and how to cross a wetland consider the following:

- There should be no need to cross a wetland if the area can be accessed through another part of the ROW. If this is not possible, then the appropriate method of crossing the wetland must be determined (See 5.7.2. & 5.7.3. to select appropriate method)
- Can the wetland be crossed without disturbing the soils or rutting the wetland? Tracked machines have a lower ground pressure than machines with tires. Crossing on existing woody debris or stones will help minimize soil disturbance
- If you are creating ruts they will need to be regraded/restored within 72 hours (See section 5.10 “Restoration”).
- If machine is expected to make ruts then the use of a mat is required. The mat can be a corduroy mat made of brush or a manufactured mat (See BMP #6 & 7).
- Once the area has been restored, any areas greater than 100 SF of disturbance should be over-seeded with an appropriate seed mix (See BMP #4).
- In any instance refer to restoration section 5.10 for specific instructions.

The examples on the following page give guidance for the relocation of access ways and how to cross wetlands where no apparent access way is available:

5.7.1. Avoidance

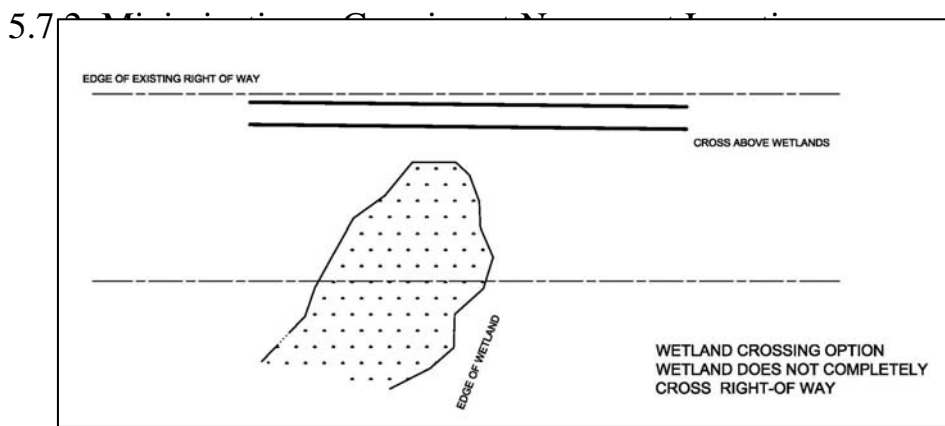

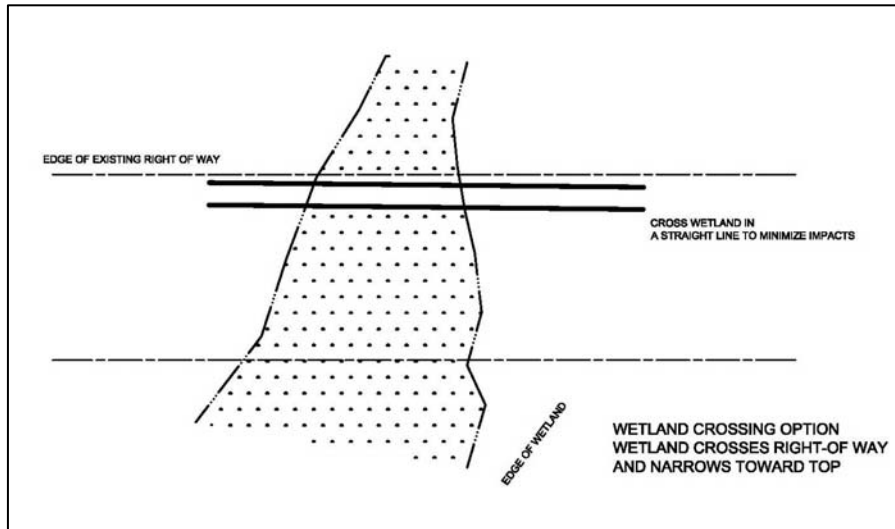

5.7.3. Minimization – Crossing Uniform Width Wetlands in a Straight Line

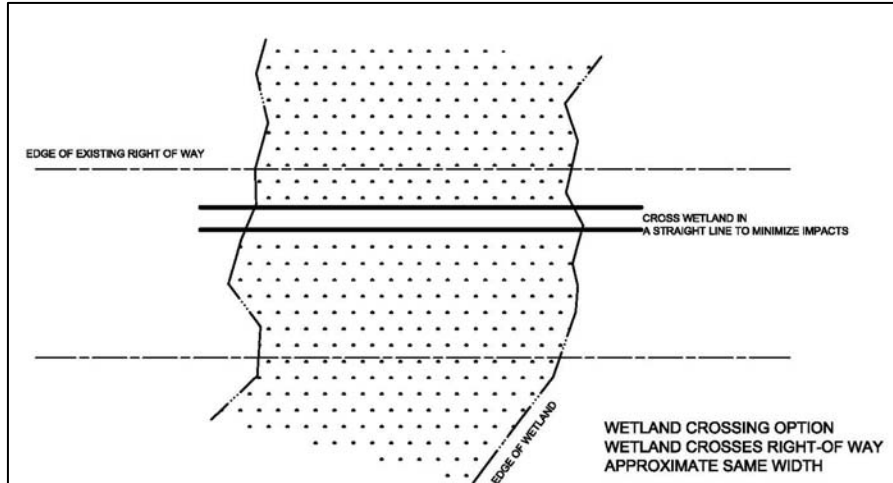

Equipment Selection and Usage

- **Low ground pressure equipment.** Using equipment that reduces the pressure that it exerts on the ground can minimize impacts to sensitive areas. Employing the use of equipment with wide tires, rubberized tracks, and low ground pressure (< 3 psi) can help minimize soil compaction.
- **Wide tires.** Increasing the width of tires will increase traveling surface area and therefore reduce the amount of ground compaction that the equipment will cause. Ultimately, this will reduce rutting, and allow for easier maneuvering of the vehicle. However, wide tires may be costly and will require a wider travel area.
- **Rubberized tracks.** Equipment with rubberized tracks spreads the weight of the vehicle over a much larger surface, reducing ground pressure and enabling the vehicle to move more freely through wet substrates. Each track can be between 1.5' and 3' wide, length depending on the width of the vehicle. This can greatly reduce rutting and allow the vehicle to move with less difficulty through wet substrates.
- **Lightweight equipment.** Impact in a wetland area can be lessened by reducing the size of equipment used in sensitive areas. This reduces the amount of pressure to the travel surface as well as the necessary width of access ways.

5.8. Stream Crossings

There are a number of BMPs that can be selected to minimize impacts on streams. Each situation should take the current site and project needs into consideration in order to select the best method which will be most cost effective and incur the fewest secondary impacts. Additional erosion and sedimentation controls (e.g. hay or straw bales) may be required in conjunction with the following stream crossing BMPs to protect sensitive areas.

Stream crossings are permitted as long as appropriate BMPs are implemented. Many streams may be crossed by tracked or rubber tired equipment/vehicles provided there is no disturbance to either the bank or the bed of the stream.

- Small streams may be straddled with tracked machines,
- Streams where damage may occur to either the bank or the bed of the stream will require the use of one of the following measures:
 - Temporary mats BMP #6
 - Poled ford BMP #8

Swamp Mats as Temporary Bridge

Swamp Mats may be used as a temporary bridge over a stream to allow vehicles access to the work site. Small sections of mat are placed within and along the stream parallel to the flow of water. These act as supports. Mats may then be placed perpendicular to the stream, resting on top of the initial swamp mat supports. It may be necessary to place a large steel plate along the top of the

swamp mats for extra stability and to minimize the amount of sediment that could fall between the spaces of each timber.

Poled Fords

In rare situations, it may be acceptable for equipment simply travel (perpendicularly) through a stream. Such crossings are generally considered acceptable where there is : 1) an intermittent flow; 2) a stable stream bottom where a historic access road has already established a perpetual disturbance; and/or 3) where the crossing is at a relatively narrow reach of the stream and any adjacent wetland. To further minimize disturbance in those areas, wood poles or saw logs of sufficient length and diameter should be lain in the stream bed parallel to the floor.

Any temporary measures employed must be removed upon completion of the job.

5.9. Invasive Species

5.9.1. Avoidance

In all cases, the best method for controlling the spread of invasive species is to avoid disturbing them. If avoidance is not possible, the crew supervisor should determine if hand cutting any woody vegetation within this area would be less of a disturbance to the plants than bringing in a machine.

5.9.2. Cuttings and Equipment Cleaning

Where it is determined that a machine must be used (e.g. in an area where purple loosestrife is interspersed with a significant amount of woody vegetation), care should be taken to limit the amount of activity within that wetland area. Additionally, any machinery that has been working in an area of invasive plants shall be inspected for foreign plant matter (stems, flowers, roots, etc.) and soil embedded in the tracks or wheels. If foreign plant matter/soil is present, the operator shall remove the plant material and soil from the machine using hand tools. If it is determined that additional cleaning measures are required, the machine shall be either pressure washed before crossing another road or transported to a wash facility before continuing to do ROW maintenance work.

Both purple loosestrife and common reed are spread by root rhizomes. Therefore, extreme care should be taken in disturbing the soils.

Additionally, these plants tend to release seed material starting in mid-July. Any equipment that enters areas at this time of the year where these plants dominate should be immediately inspected and cleaned prior to continuing any work.

Guidance related to equipment operation, cleaning, etc in areas impacted by invasive species is available from the NH Department of Agriculture, and the NH Department of Transportation. Links to applicable guidance documents and fact sheets are listed in Appendix B of this document.

5.10 Restoration of Disturbed Areas

If an area has been disturbed, it will likely require a level of restoration. The following table outlines basic measures required for restoration, and sections 4.10.1 & 4.10.2 provide additional information.

Restoration Table						
	Regrade	Mulch	Seeding	Inspect	Maintain	Std Appl**
Ruts < 8"	X					
Ruts > 8"	X	X				
Exposed soil in Wetland	X	X	X	X	X	
Exposed soil in Upland*	X	X				
Impacts < 3000 sq. ft.	X	X	X	X	X	
Impacts > 3000 sq. ft.	X	X	X	X	X	X
*Note - Action would only be required if disturbed upland soils could adversely impact an adjacent wetland or waterbody **Note – Standard Dredge and Fill Application or Emergency Permit						

5.10.1. Wetland Restoration

In the event that rutting or disturbance has occurred within wetland areas, the following procedures shall be implemented:

- Impacts with ruts < 8" - After the machine has crossed for the last time the area shall be smoothed either by the machine or hand rakes. In general, if the restoration occurs within the same day as the initial disturbance, it is expected that the vegetation will not be significantly disturbed and should regenerate with no other action.
- Impacts with ruts > 8" - This area may also need additional or more substantial regrading. To further augment the restoration seed and mulch will be applied to stabilize the area. See BMPs # 4&5.
- If the individual impact area is larger than 3,000 SF or impacts areas outside the scope of this manual, then an after the fact report including photos shall be submitted to the utility service provider.

5.10.2. Upland Restoration

If exposed soils could present sedimentation issues to adjacent wetlands and waterbodies, permanent soil protection shall be provided.

If needed, topsoil will be replaced and the area seeded, and mulched (See BMPs # 4&5).

Rehabilitation of access routes and other areas must be done as soon as possible after project is complete. This includes the reestablishment of waterbars or other BMPs to control erosion of the access way as well as the removal of temporary BMPs.

Access road stabilization, temporary or permanent seeding of disturbed areas, seed selection, application rate, timing and method, should be performed in accordance with the BMPs #4, 5 & 9.

5.10.3. Regrading

In the event that regrading of either wetland or upland areas is necessary, one of the following procedures shall be implemented:

- Hand Methods
 - Shovels, Rakes, hand tampers can be used to restore rutting/compaction to its pre-existing grade
- Machine Methods
 - Tracked machines, buckets of backhoes, or other appropriate machines can be used if they do not create additional rutting or compaction of the soils.

5.11 Inspection and Maintenance

Inspections are required on all work areas where BMPs in Appendix A have been implemented. The BMPs employed are temporary in nature and require frequent inspection and maintenance to remain effective. **Repairs must be performed immediately when a control measure is found to be deficient.**

5.12 Best Management Practices (BMPs)

BMP #	Measure	Page
1	Silt Fence	32
2	Weed Free Bale Barrier	35
3	Silt Fence / Weed Free Bale Barrier	37
4	Seeding Options	41
5	Appropriate Mulching Material	44
6	Prefabricated Mats	45
7	Corduroy	48
8	Poled Ford	49
9	Access Way Stabilization	51
10	Reinforced Silt Fence	53
11	Sediment Filter	54
12	Stone Check Dams	55
13	Earth Dike / Drainage Swale and Lined Ditch	57
14	Dewatering	60

SILT FENCE

BMP #1

A silt fence is a temporary geotextile fabric sediment barrier intended to intercept sediment-laden water. A silt fence is designed to trap water from small watersheds of less than 2 acres and is not a filter.

Appropriate Applications:

Silt fences are placed:

- Around temporary stockpiles.
- Up slope of wetlands and streams as a barrier.
- Along the edge of access ways and along the perimeter of work zones adjacent to wetlands or waterbodies.
 - Along streams and channels.
 - Below the toe of exposed and erodible slopes.
 - Down slope of exposed soil areas.

Limitations:

- Improperly installed, (i.e. not trenched and keyed) will cause problems by concentrating flows and directing storm water to undesirable areas.
- Must be removed and disposed of when work is complete.
- Cannot be installed across streams, ditches, channels or areas of concentrated flow.
- Cannot be used to divert flow. Silt fence must be placed along the contour to allow the water to spread out.

Standards and Specifications:

- The maximum slope length above a silt fence should comply with the following table:

Slope (Horizontal Distance for 1 foot change vertically)	Maximum Slope Distance above silt fence
2:1	50
3:1	75
4:1	125
5:1	175
Greater than 5:1	200

- Silt fences work by ponding water and allowing sediment to settle out behind it. Ensure that the location is suitable for temporary ponding or deposition of sediment. (E.g. do not place silt fence in a wetland and have the water pond within the wetland, instead place the silt fence above the edge of the wetland.)
- Silt fences deteriorate over time and have a typical lifespan of less than 1 year. Longer periods of use will require silt fences to be replaced.
- Silt fences shall not be used in areas of concentrated flow.

Materials:

- Silt fence fabric shall be woven polypropylene with a minimum width of 900 mm (36 inches) and a minimum tensile strength of 0.45-kN. The fabric shall conform to the requirements in ASTM designation D4632 and shall have an integral reinforcement layer. The reinforcement layer shall be a polypropylene, or equivalent, net provided by the manufacturer. The permittivity of the fabric shall be between 0.1 sec^{-1} and 0.15 sec^{-1} in conformance with the requirements in ASTM designation D4491.
- Wood stakes shall be commercial quality lumber of adequate size and shape. Stakes shall either be pre-applied to the fence or spaced no further than 6 feet apart during installation.

Installation:

- Bottom of the silt fence shall be keyed in a minimum of 6 inches.
- Trenches shall not be excavated wider and deeper than necessary for proper installation of the temporary linear sediment barriers.
- Silt fences shall be placed at least 3 feet off the top of slope where appropriate.

Maintenance and Inspection:

In addition to Section 5.11 of this manual, perform maintenance and inspection as follows:

- Repair or replace split, torn, slumping, or weathered fabric.
- Maintain silt fences to provide an adequate sediment holding capacity. Sediment shall be removed when the sediment accumulation reaches one-third of the barrier height, typically 8 inches.
- Remove silt fence when no longer needed. With native soil, fill and compact post holes and anchorage trench, remove sediment accumulation, and grade fence alignment to blend with adjacent ground.

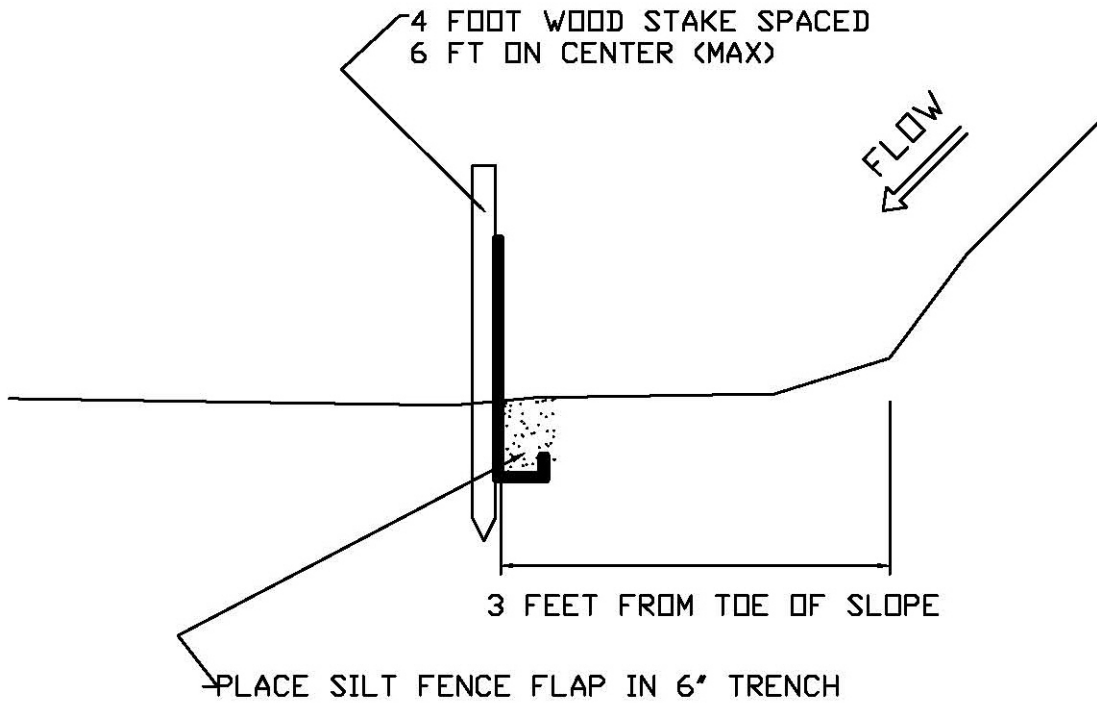

WEED FREE BALE BARRIER

BMP#2

A weed free bale barrier (bale barrier) is a temporary perimeter sediment barrier consisting of a trench and staked bales. The bale barrier is designed to intercept and trap sediment present in surface water run-off. Bale barriers allow sediment to settle from runoff before water leaves the construction site. It's important to use weed free bales (straw, weed free hay or chip bales) because regular hay bales have a high potential of containing invasive species.

Appropriate Applications:

This perimeter control is an alternative to silt fence. Appropriate applications include:

- Along the edge of access ways and along the perimeter of work zones adjacent to wetlands or waterbodies.
 - Along streams and channels.
 - Below the toe of exposed and erodible slopes.
 - Down slope of exposed soil areas.

Limitations:

- Bale barriers are maintenance intensive. These measures have a short useful life and must be replaced about every 2 months to be effective.
- Degraded bales may fall apart when removed or left in place for extended periods.
- Bale barriers shall not be used in areas of concentrated flow.

Installation:

- Bales must be installed in a shallow trench
- Bales must tightly abut adjacent bales
- Bales must be staked
- Construct bale barriers with a setback of at least 3 ft from wetlands and waterbodies where practical.

Maintenance and Inspection:

In addition to Section 5.11 of this manual, perform maintenance and inspection as follows:

- If sediment has built up more than 8", remove sediment and dispose of outside of wetlands or waterbodies.
- Replace or repair bales as needed (e.g. washouts, damaged bales, etc.).
- Remove bales when no longer needed. Remove sediment accumulation, and clean, regrade, and stabilize the area. Removed bales can be used as mulch for restoration efforts (see BMP #5).

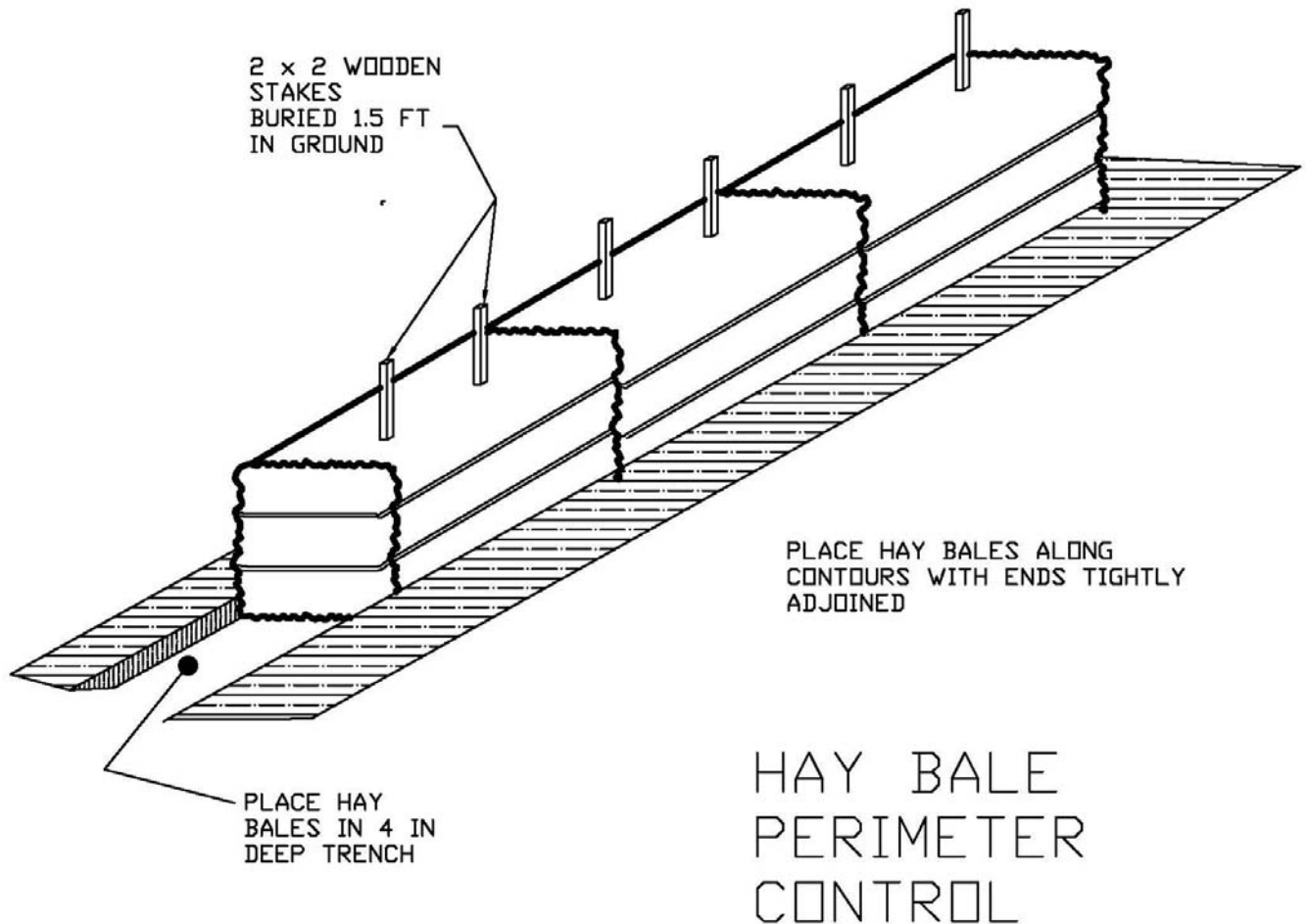

SILT FENCE / WEED FREE BALE BARRIER

BMP#3

A silt fence bale barrier is a temporary perimeter sediment barrier consisting of a trenched silt fence and staked bales. The double barrier is designed to intercept and trap sediment in critical areas where normal BMP measures may not suffice. It's important to use weed free bales (straw or weed free hay) because regular hay bales have a high potential of containing invasive species.

Appropriate Applications:

This perimeter control is an alternative to either silt fence or bales alone. Appropriate applications include:

- Along the edge of access ways and along the perimeter of work zones adjacent to wetlands or waterbodies.
 - Along streams and channels.
 - Below the toe of exposed and erodible slopes.
 - Down slope of exposed soil areas.
- In areas where there is a higher amount of concentrated flow and a typical silt fence installation would not effectively contain storm water runoff.
- In areas where the barrier must be placed at the immediate toe of a steep slope with no other options for diverting or containing storm water.

Limitations:

- In order to work properly, this measure must be properly trenched. Failure to do so will cause sediment-laden water to run under or around the measure.
- Bale barriers are maintenance intensive. These measures have a short useful life and must be replaced about every 2 months to be effective.
- Degraded bales may fall apart when removed or left in place for extended periods.

Installation:

- A shallow trench must be constructed prior to installation.
- Place the silt fence at the down-slope side of the trench with the flap extending into the trench.
- Bales must tightly abut adjacent bales
- Bales must be staked
- Construct bale barriers with a setback of at least 3 ft from wetlands and water bodies where practical.

- Extend silt fence for at least 10 feet beyond the bales and curve the ends up slope to allow storm water to be trapped by the measure

Maintenance and Inspection:

In addition to Section 5.11 of this manual, perform maintenance and inspection as follows:

- If sediment has built up more than 8", remove sediment and dispose of outside of wetlands or waterbodies.
- Replace or repair silt fence and bales as needed (e.g. washouts, damaged bales, etc.).
- Remove BMP when no longer needed. Remove sediment accumulation, and clean, regrade, and stabilize the area. Removed bales can be used as mulch for restoration efforts (see BMP #5).

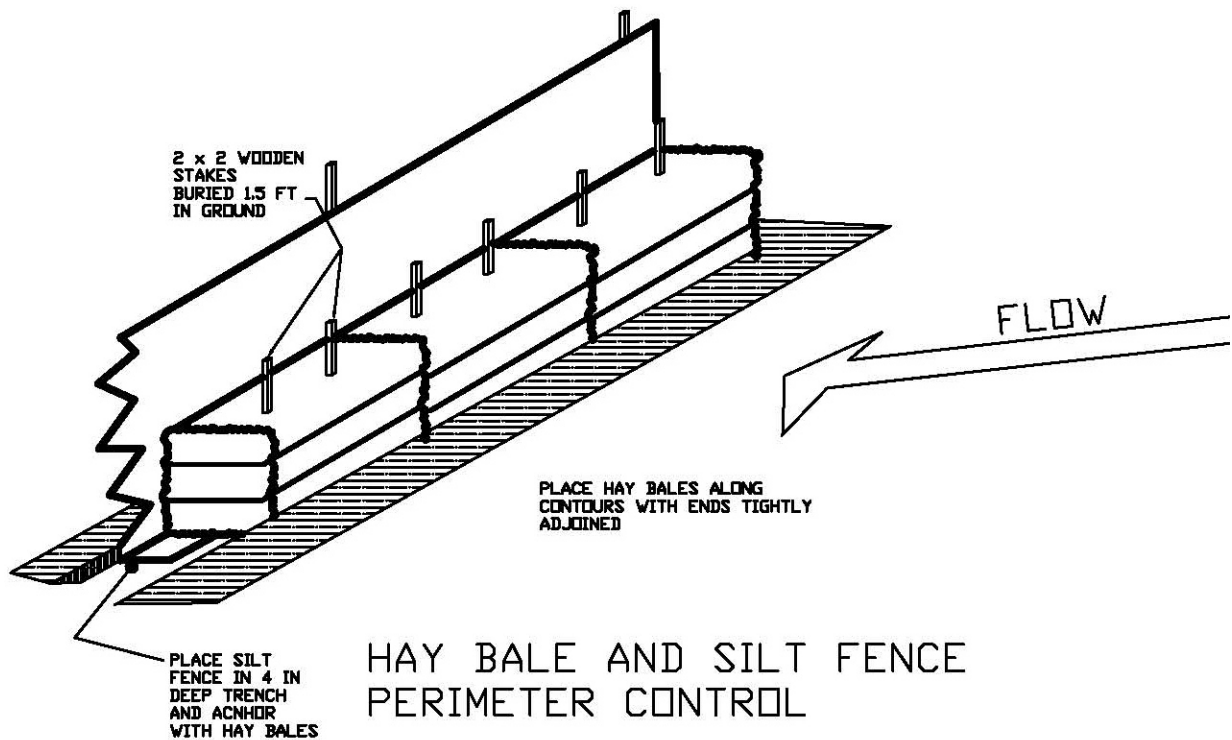

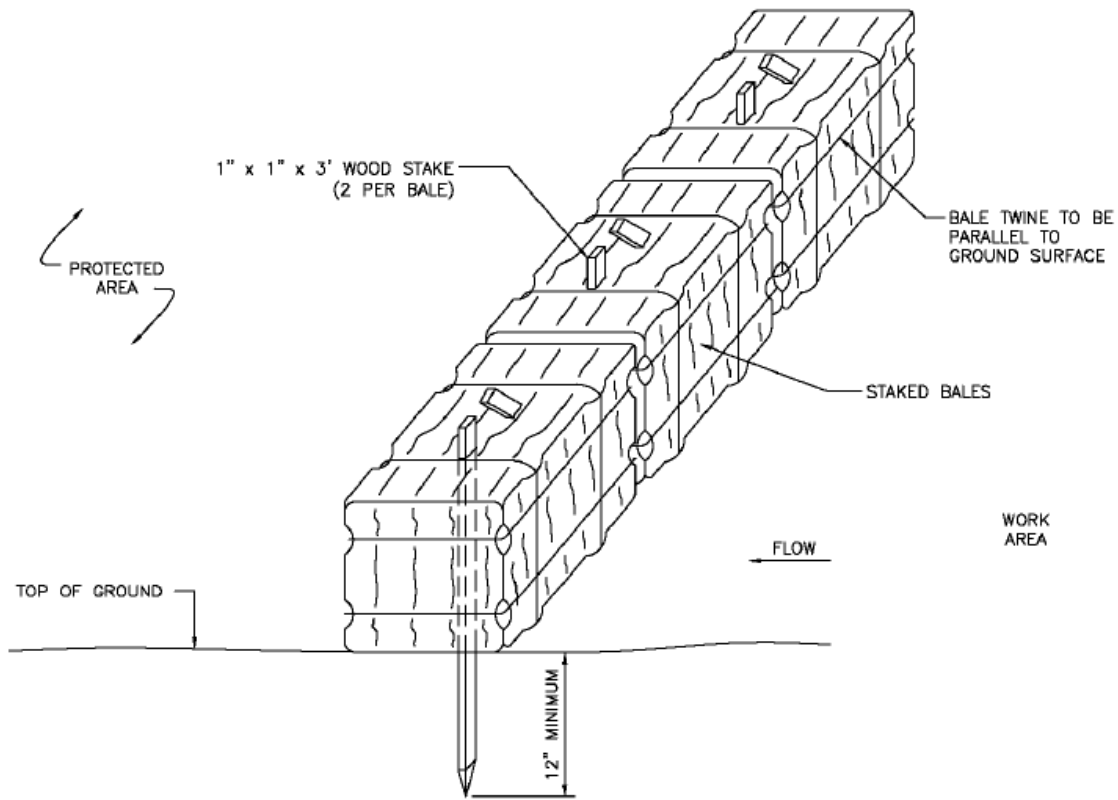

TYPICAL NONEMBEDDED SEDIMENT
BARRIER INSTALLATION

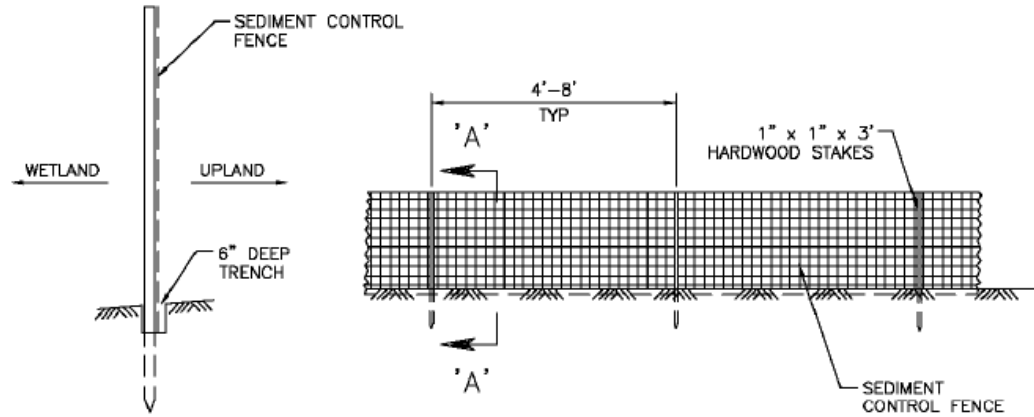

SECTION A-A

TYPICAL SEDIMENT
CONTROL FENCE

SEEDING OPTIONS

BMP #4

A temporary or permanent establishment of vegetation will reduce the erosion potential of an area by over 90%. The goal of the seeding mix is to stabilize the area while allowing the native seed stock to re-establish in the area.

Application:

Seeding shall be done on any disturbed area over 100 SF in and immediately adjacent to wetlands. Seed mix shall be applied at the rate specified by the manufacturer. A layer of mulch (BMP #5) shall be applied over all seeded areas.

Limitations:

When seeding in wetlands choose from the list but check seed mix to ensure that there is no clover or crown vetch in the package.

Seeding Option:

If seeding by hand is not practical, hydroseeding can be used. Hydroseeding is a spray on mixture usually consisting of a seed mix with a mulch and tackifier to hold it in place. The mulch varies from paper, to wood, to newer products identified as bonded fiber matrices. The hydroseeding mix can also include fertilizers.

Hydroseeding is applied on disturbed soil areas requiring temporary protection until permanent vegetation is established or disturbed soil areas that must be re-disturbed following an extended period of inactivity.

Seeding Mixtures for Permanent Seedings

Seed Mix	Preferred Species	Commercially Available Mix	Commercially Available Mix
		Species (%)	Species (%)
Wetland or Moist Area		Agway Conservation Mix	Blue Seal Rockingham SCS Mix
	Perennial Rye Grass	X (31)	
	Birdsfoot Trefoil		X (20)
	Redtop		X (10)
	Tall Fescue		X (40)
	Creeping Red Fescue	X (25)	X (30)
	Annual Rye Grass	X (18)	X (15)
	Kentucky Bluegrass	X (20)	
Application Rate		2 LBS/ 1,000 SF	1 LB / 1,000 SF

Dry / Upland Areas		Agway Landscape Mix	Blue Seal Rockingham Soil/ Vermont Conservation Mix
	Flatpea		
	Birdsfoot Trefoil		
	Redtop		
	Tall Fescue		X (25)
	Creeping Red Fescue	X (16)	X (35)
	White Clover		X (3)
	Crown vetch		
	Kentucky Blue Grass	X (15)	X (10)
	Annual Rye		X (15)
	Perennial Rye	X (67)	X (12)
Application Rate		5 LB / 1,000 SF	1.5 LBS / 1,000 SF

Note: Seed disturbed areas as soon as possible. When possible, seed early in the spring as soon as the ground can be worked and in the late summer/early fall. Include 10-20 lbs./ac. of winter rye when seeding after Sept. 15th. On critical areas or droughty sites, mulch at the rate of 90 lbs./1000 sq. ft. Anchor mulch on steep slopes or where subjected to concentrated flow. Inoculate legumes separately with appropriate seed specific inoculants.

If seeding after October 15th use either winter rye or a 50/50 blend of annual and perennial rye grass.

In the event that seed mix does not germinate properly, have soils tested for nutrients and pH. If soil test recommends a fertilizer, apply at rate recommended in test.

APPROPRIATE MULCHING MATERIALS

BMP #5

Mulch is an inexpensive and easily applied cover for any exposed or recently seeded soil. Mulch at a rate of 2000 lbs. per acre has been shown to reduce the erosion potential by 90% when properly applied. Mulching materials include but are not limited to:

- Straw
- Weed free hay (Salt marsh hay)
- Coconut Matting/Fiber matting
- Filter Fabric

Applications:

- Mulch is used as a temporary cover that will protect an area as the site is re-vegetating.
- Mulch is used in conjunction with temporary or permanent seeding to facilitate plant growth.

Limitations:

- If mulch is not properly anchored, it will have a tendency to either be blown or washed away.
- If applied during the dormant season, it may have to be removed prior to permanent seeding. However, it should be noted that seeding could be done in the dormant season with the mulch placed on top.
- On steep slopes and areas of concentrated flows, mulch will not stay in place. In some circumstances a more substantial cover such as an erosion control blanket may be required.

Maintenance and Inspections:

- Mulch needs to last long enough to achieve erosion control objectives, either over winter protection or protection until vegetation becomes established. If mulch has been blown or washed away, additional applications may be required.
- Mulch should provide a uniform, 2” cover over exposed soils. Inspect and add additional mulch as necessary until the erosion control objective is reached.

PRE-FABRICATED MATS

BMP#6

Pre-fabricated mats are pads that can support the weight of equipment and prevent both rutting and disturbance of soils. These mats can be used for crossing wetlands or watercourses, or for providing a stable work platform to conduct repairs and maintenance activities. Mats are constructed of several different types of materials including wood and plastic.

Guidelines:

- Placement of mats should be in a location that would minimize the length needed for crossing (See Section 4.7. of this manual).
- Mats may be used to cross small streams provided the mat does not disturb the bed or banking (See Section 4.8. of this manual).
- Where possible, mats should be placed so that they are not overtopped with water and equipment can work in the dry.
- Mats shall be removed from wetland areas once the crossing or maintenance activity is completed.

Limitation:

- Mats shall not be placed so that they restrict the natural flow of water.
- Mats that have been placed in areas of invasive species shall not be used again until they have been cleaned and inspected (See Section 5.9.2. of this manual).

Installation:

- Install and remove in accordance with manufacturers instructions, if applicable.
- Every effort should be made to minimize impact to wetland areas during installation, use, and removal.

Inspections:

- Inspect after each use:
 - Look for any defects or structural problems.
 - Inspect for any plant material left on mats, remove immediately

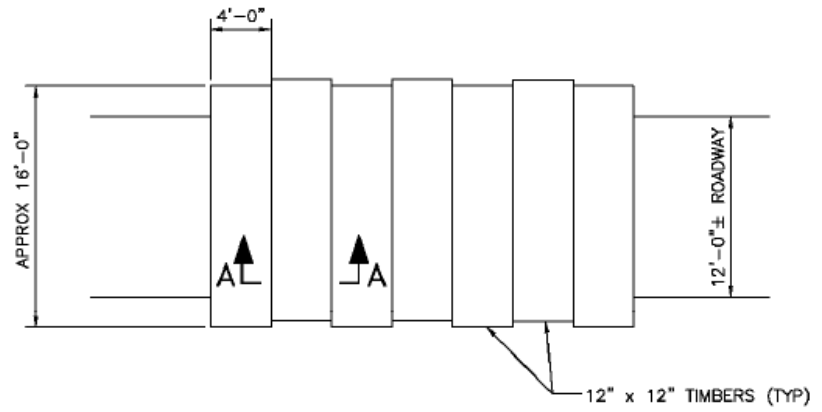

TYPICAL PLAN VIEW

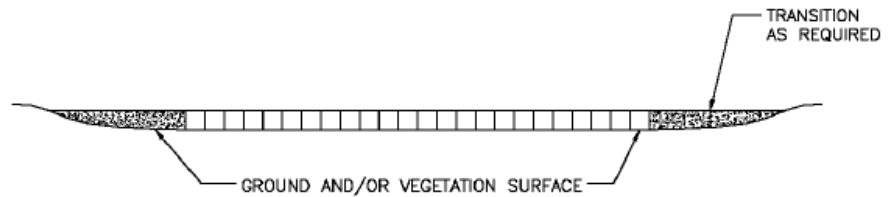
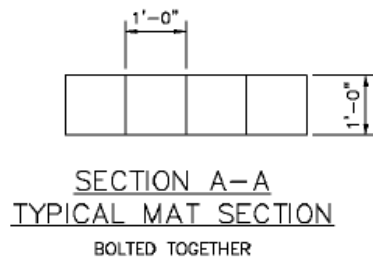

TYPICAL SECTION VIEW

NOTE:

1. TO BE INSTALLED IF NECESSARY TO PREVENT RUTTING, TO ACCESS STRUCTURES.
2. THIS DETAIL SHOWS TYPICAL DIMENSIONS. SOME CONTRACTORS SWAMP MATS ARE DIMENSIONALLY DIFFERENT FROM WHAT IS SHOWN HERE.
3. DEPENDENT ON SITE CONDITIONS, MULTIPLE LAYERS OF SWAMP MATS MAY BE INSTALLED.

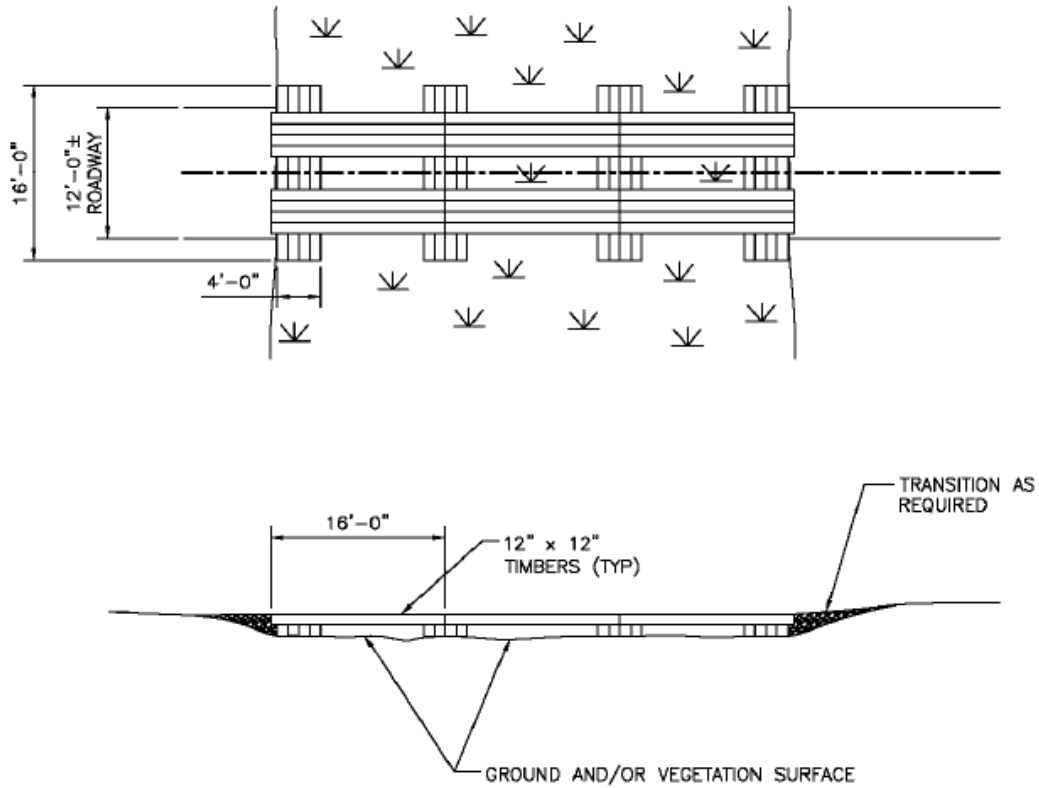

TYPICAL STREAM CROSSING
WITH SWAMP MATS

CORDUROY

BMP #7

Corduroy is a soil stability technique where logs and brush are cut from the immediate area and used as a road bed to prevent rutting from equipment crossing. This technique is designed to be used in areas of wetland crossings where there is no defined channel or stream flow.

Applications:

- The crossing of wetlands and wet soils (spring conditions) where soils are subject to rutting.

Limitations:

- Not to be installed in streams.
- To be placed in the narrowest area practicable for crossing.

Guidelines:

- Place 8 - 10 inch diameter poles or cull logs side by side in wet area to serve as an access way.
- Place poles or cull logs perpendicular to the direction of travel across wet area.
- The top width of corduroy shall not exceed 12 feet.
- Shall not be crossed when they are overtopped with water.
- May be left in place for use on next maintenance cycle.
- Corduroy access ways shall be inspected prior to use and repaired as needed.

POLED FORDS

BMP#8

Poled fords are used to assist in temporary stream crossings within a defined channel, using poles, cull logs or other appropriate materials as the roadbed. These are used as temporary crossings instead of placement of a bridge or culvert. Poled fords can be constructed and used during periods of no or low flow. Fords are used for crossing streams with equipment where there is limited potential for sedimentation of the stream.

Guidelines:

- Fords are prohibited on all streams in watersheds tributary to drinking water intakes or reservoirs for public and private water supplies, where ford is within 2,000 feet of such intakes or reservoir.
- Shall not be crossed when they are overtopped with water.
- Constructed on sound stable stream bottoms.
- Use geo-textile fabric or other appropriate bedding if needed to stabilize the approaches to the crossing.
- Find stream banks that are firm and level with approaches that are reasonably level for a distance of 50 feet on each side of the stream crossing.

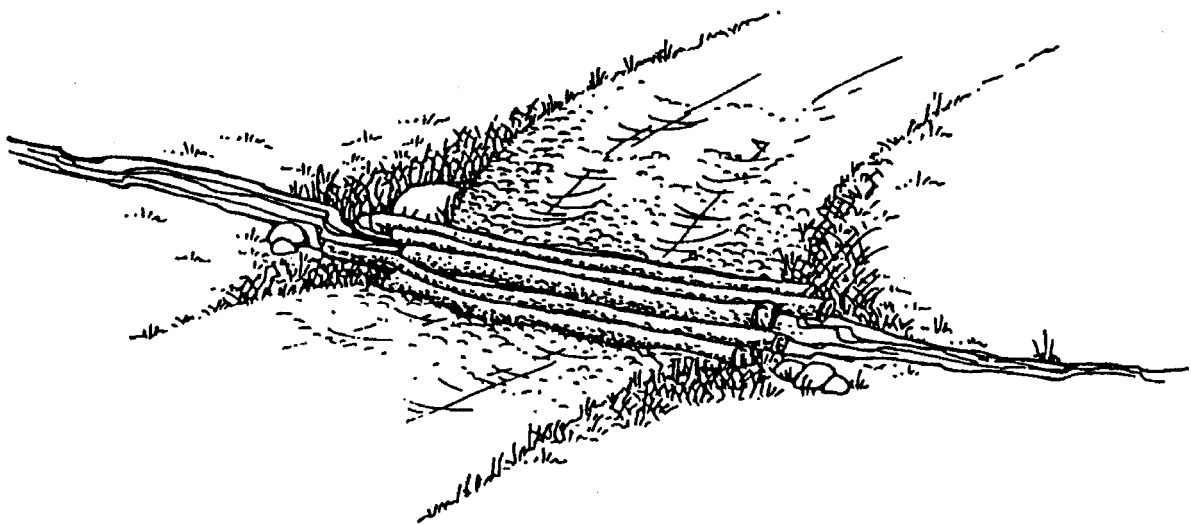

- Place 8 - 10 inch diameter poles, cull logs or other appropriate material side by side on the streambed to serve as the roadbed.
- The top width of these fords should be at least 10 feet.
- After fords have been overtopped with water, repair and maintenance may be required.
- Poled fords should be inspected regularly to make sure sedimentation is not entering the stream.
- Do not place gravel or fill over poled fords.
- Poled fords must be removed immediately after completion of maintenance activity.

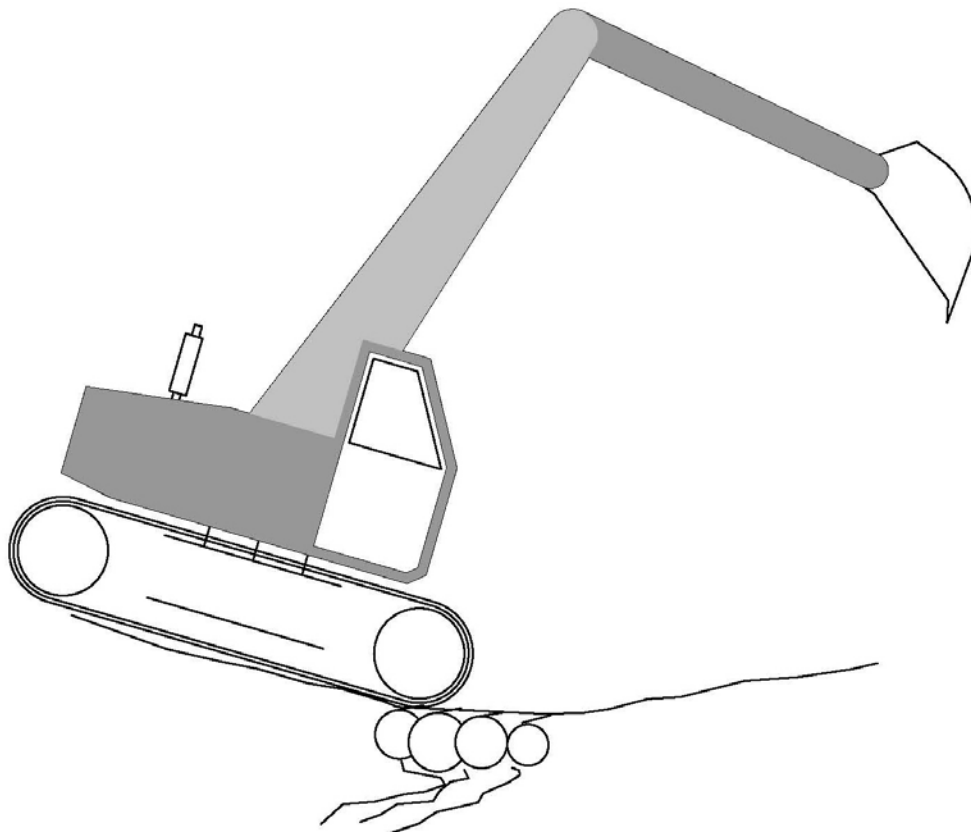

ACCESS WAY STABILIZATION

BMP #9

In order to prevent erosion or sedimentation issues when working adjacent to wetlands or waterbodies, it is essential that upland soils are stabilized. Planting vegetation such as grasses and legumes on exposed mineral soil and erodible access ways will ensure proper stabilization.

Appropriate Application:

- This measure is intended to be used where exposed soils are subject to erosion and where a permanent vegetative cover is needed.

Installation:

- Where feasible, prepare a seedbed by grading, removing debris, and scarifying the soil to a minimum depth of 3 inches. When the area to be seeded has been recently loosened to the extent that an adequate seedbed exists, no additional treatment is required.
- Seed should be applied as indicated in BMP #4 (Seeding Options).
- Track in seed with a dozer whenever possible to improve germination and establishment, especially when seeding on sandy, droughty sites.
- Mulch shall be applied over all newly seeded areas at a rate of 2 tons per acre. Mulch will retain soil moisture essential to seed germination, and additionally will protect the soil surface from erosion. See BMP#5.
- Inspect all seeded areas in accordance with Section 5.11 of this manual.

Appropriate Application:

- **This measure is intended for access to a public road from a ROW where sediment may be tracked onto the public road.**

Installation:

- **Install rock apron located from ROW to public road as shown below:**

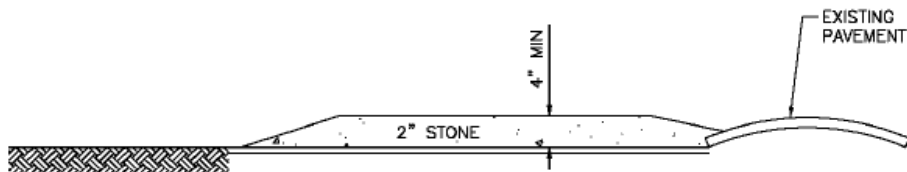
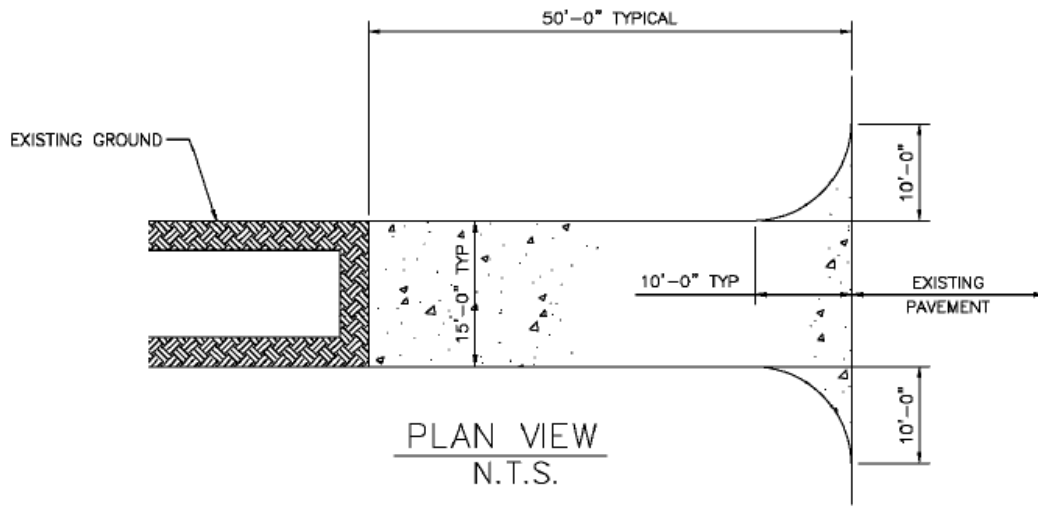

CONSTRUCTION SPECIFICATIONS

1. STONE SIZE - USE 2" STONE (MINIMUM) TO 6" STONE (MAXIMUM)
2. LENGTH - GREATER THAN OR EQUAL TO 50 FEET
3. THICKNESS - 4"
4. WIDTH - FIFTEEN (15) FOOT TYP., BUT NOT LESS THAN THE FULL WIDTH AT POINTS WHERE INGRESS OR EGRESS OCCURS.
5. SURFACE WATER - ALL SURFACE WATER FLOWING OR DIVERTED TOWARD CONSTRUCTION ENTRANCES SHALL BE PIPED ACROSS THE ENTRANCE. IF PIPING IS IMPRACTICAL, A MOUNTABLE BERM SHALL BE PERMITTED.
6. MAINTENANCE - THE ENTRANCE SHALL BE MAINTAINED IN A CONDITION WHICH SHALL PREVENT TRACKING OR FLOWING OF SEDIMENT ONTO PUBLIC RIGHTS-OF-WAY. THIS MAY REQUIRE PERIODIC TOP DRESSING WITH ADDITIONAL STONE AS CONDITIONS DEMAND AND REPAIR OR CLEANOUT OF ANY MEASURES USED TO TRAP SEDIMENT. ALL SEDIMENT SPILLED, DROPPED, WASHED OR TRACKED ONTO PUBLIC RIGHTS-OF-WAY MUST BE REMOVED IMMEDIATELY.
7. PERIODIC INSPECTION AND NEEDED MAINTENANCE SHALL BE PROVIDED.
8. DEPENDING UPON SITE CONDITIONS, THIS ENTRANCE MAY OR MAY NOT BE PERMANENT

REINFORCED SILT FENCE

BMP#10

The Reinforced Silt Fence is designed to work in severe conditions such as the toe of steep slopes, severe grades and stream protection. It is intended for areas with larger drainage areas than typically appropriate for normal silt fence installation and can add extra siltation protection.

The Recommended maximum spacing between the metal drive posts is 10'.

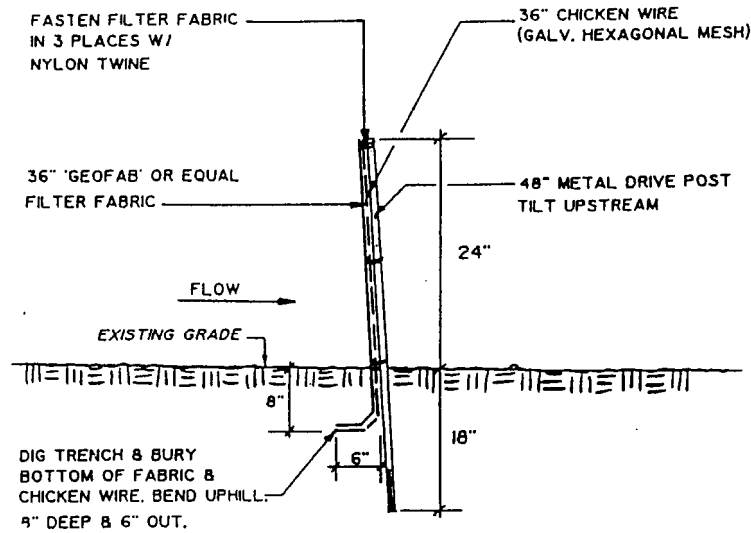

REINFORCED SILT FENCE

NOT TO SCALE

SEDIMENT FILTER

BMP #11

The sediment filter is to be placed at a point of discharge. Length is determined by the acreage and gradient of run-off during the construction activity. Staked bales or geotextile fabric should be used to direct the run-off to the sediment filter. (The illustration and dimensions shown below are for visual means only.)

Application:

This measure can be used in conjunction with silt fence, reinforced silt fence or bale barriers where a controlled outlet is necessary or desirable.

$W = 5' \times L = 10'$, is the recommended minimum dimension when you are collecting run-off at a low point and releasing it into a regulated discharge area.

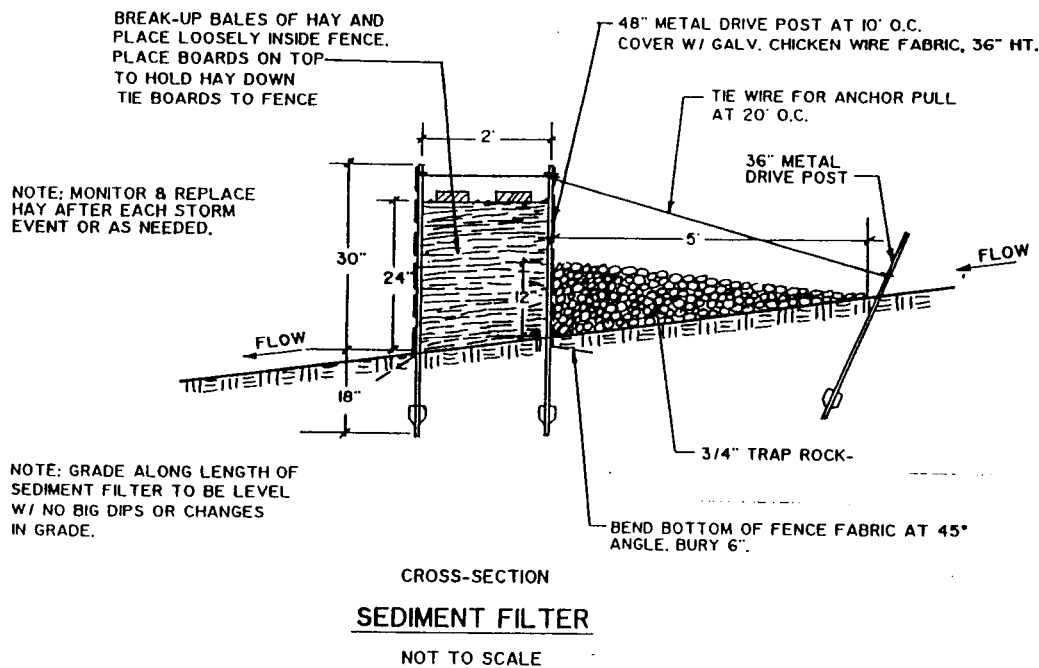

STONE CHECK DAMS

BMP #12

Check dams are stone structures designed for placement in swales and ditches where concentrated flows occur. They are used to reduce the velocity of the water as it travels down slope. By slowing the water, the check dam helps to reduce scouring and helps to maintain a stable channel. Although check dams often help in trapping sediment that is not their main function.

Applications:

- Used on steep channels to reduce velocity of run off water, thereby mitigating erosion.

Limitations:

- Not to be installed in streams.
- Not for large drainage areas. When in doubt of total drainage area consult USGS map for area.

Standards and Specifications:

- Check dams shall be placed at a distance and height to allow small pools to form behind them.
- The spacing should be such that the toe of the upper dam is at the same elevation as the top of the next stone dam downstream.
- Stone shall be a minimum of $D_{50}=4$ inches.

Maintenance and Inspection:

In addition to Section 5.11 of this manual, perform maintenance and inspection as follows:

- Remove sediment when depth reaches one-third of the check dam height.
- Remove accumulated sediment prior to permanent seeding or soil stabilization.
- Remove check dam and accumulated sediment when check dams are no longer needed.

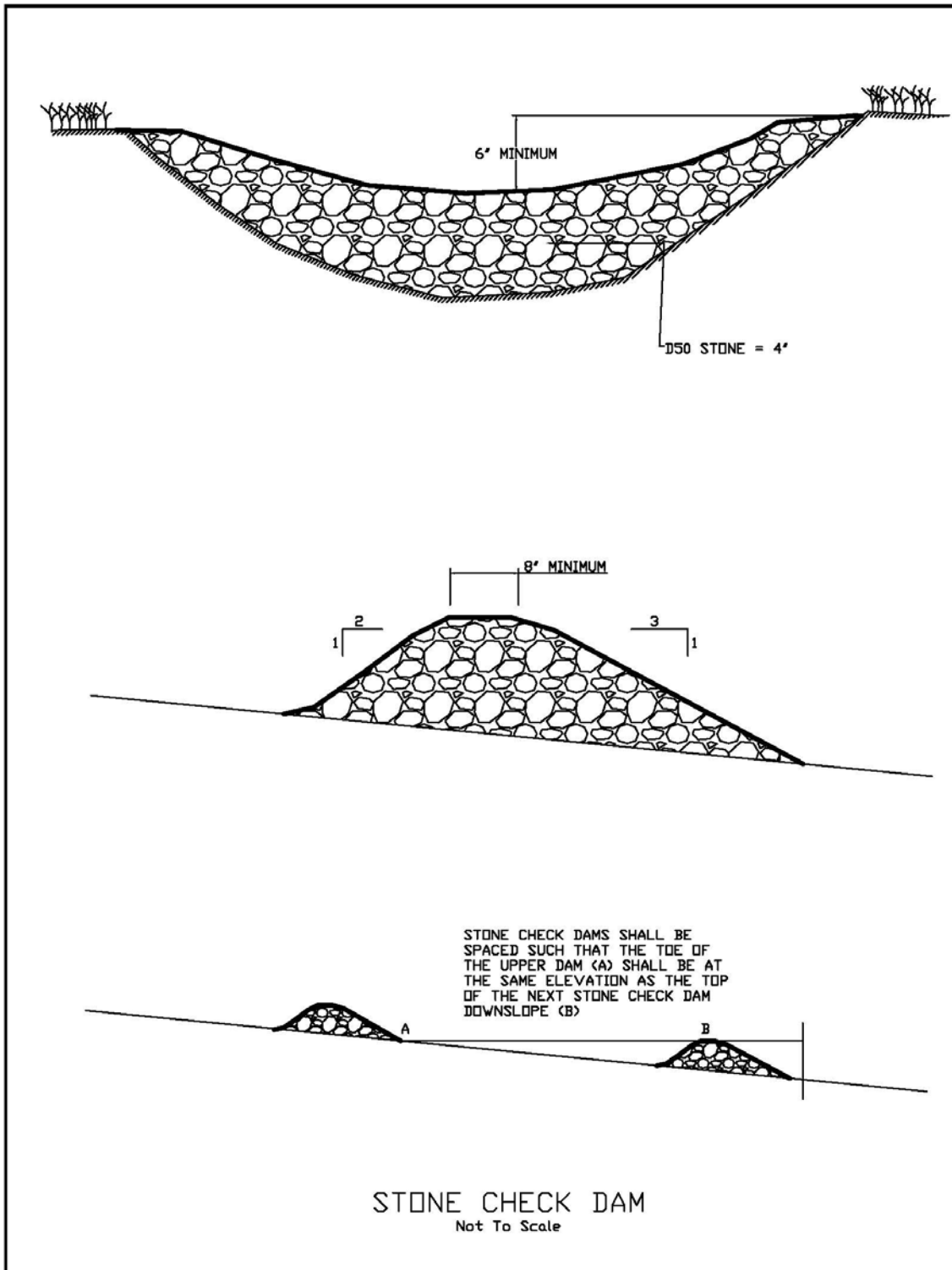

EARTH DIKE DRAINAGE SWALES AND LINED DITCHES

BMP #13

Earth Dikes, Drainage Swales and Lined Ditches are measures designed to intercept and convey water in a controlled manner. These are either used to divert water away from a work zone or toward a controlled exit point that will not create any adverse environmental impact.

Appropriate Applications:

- Convey surface runoff down sloping land.
- Intercept and divert runoff to avoid sheet flow over sloped surfaces.
- Divert and direct runoff towards a stabilized watercourse, drainage pipe or channel.
- Intercept runoff from paved surfaces.
- Below steep grades where runoff begins to concentrate.
- Along roadways and facility improvements subject to flood drainage.
- At the top of slopes to divert run-on from adjacent or undisturbed slopes.
- At bottom and mid-slope locations to intercept sheet flow and convey concentrated flows.

Limitations:

- These structures are not suitable as sediment trapping devices. Excess sediment in these structures will cause them to fail.
- These structures may need other measures to provide stability within the measure to prevent erosion. These additional measures can include any of the following: check dams, plastics, and blankets, or vegetation.

Standards and Specifications:

- Care must be applied to correctly size and locate earth dikes, drainage swales and lined ditches. Excessively steep, unlined dikes and swales are subject to erosion and gully formation.
- Conveyances shall be stabilized.
- Use a lined ditch for high flow velocities.
- Select flow velocity based on careful evaluation of the risks due to erosion of the measure, soil types, over topping, flow backups, washout, and drainage flow patterns for each project site.
- Compact any fills to prevent unequal settlement.

Maintenance and Inspections:

- Inspect ditches and berms for washouts. Repair as needed.
- Inspect channel linings, embankments, and beds of ditches and berms for erosion and accumulation of debris and sediment. Remove debris and sediment, and repair as needed.
- Temporary conveyances shall be completely removed as soon as the surrounding drainage area has been stabilized, or at the completion of construction.

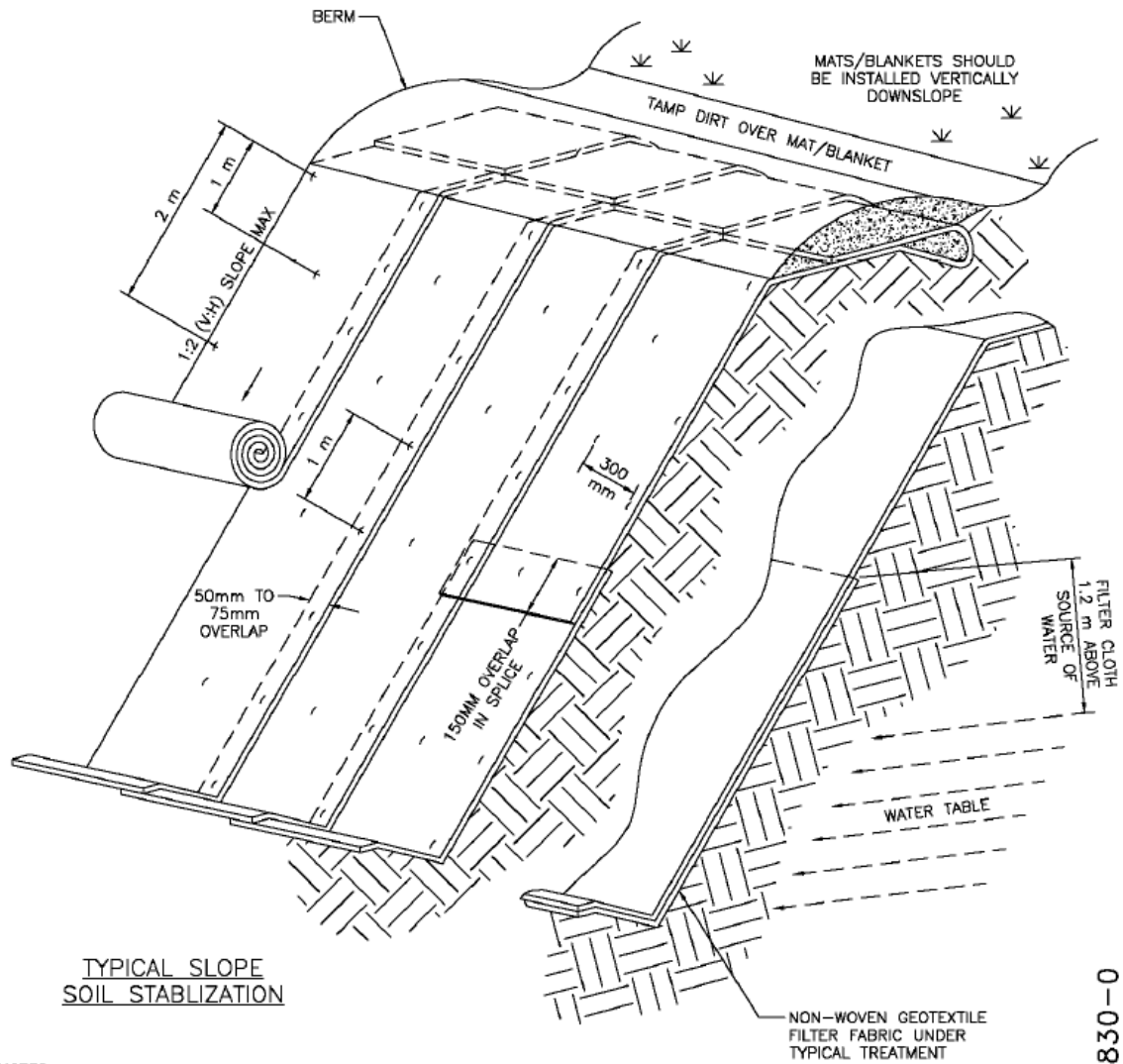

TYPICAL SLOPE
 SOIL STABILIZATION

WET SLOPE LINING

NOTES:

1. SLOPE SHALL BE FREE OF ROCKS, CLODS, STICKS, ETC AND GRADED UNIFORMLY SO MAT HAS GOOD SOIL CONTACT.
2. SIMILAR MATTING TO BE USED IN SWALES.
3. INSTALL PER MANUFACTURER'S RECOMMENDATIONS.

TYPICAL REPRESENTATION OF
 SLOPE/SWALE STABILIZATION

LS-6830-0

Dewatering

BMP# 14

Dewatering is a tool that would be rarely used, but in the event excessive water is encountered while performing work, dewatering may be necessary. Dewatering is used to either lower the water level in the immediate work zone or used to remove water that is flowing into the work zone.

Applications:

- Where ground water levels need to be temporarily lowered to allow maintenance work.
- Where drainages or storm water flows into an active work zone and is limiting the ability of personnel to complete a maintenance project.

Limitations:

- Drainage water should not be diverted to a wetland or waterbody
- Water may be turbid and depending on the particle size in the water, it may be difficult to settle out the fines.
- Dewatering will require additional equipment to be on site. Follow general management practices for all activities (Sec 4.2)

Guidelines:

- Dewatering shall be done with a sump pit, created in the smallest area needed to effectively collect the water.
- Dewatering must be done in such a way to minimize turbidity. If turbid water results, control measures must be employed.
- No discharge point shall be within 20 feet of a wetland or 50 feet of a waterbody.
- Sumps may be constructed either by creating shallow depressions or by using a perforated vertical pipe surrounded by stone.
- Monitor the discharge to ensure that no turbid water is reaching a wetland or waterbody. In the event that turbid water is reaching a wetland or water body, immediately shut down the operation and relocate the discharge point further from the resource area.

- Ensure that discharge occurs onto a non-erosive surface. Non-erosive surfaces can include rocks either natural or processed, wood debris, plastic liners or sections of larger pipes.
- If additional settling is needed for the discharge, create a ring of bales or silt fence to discharge into.

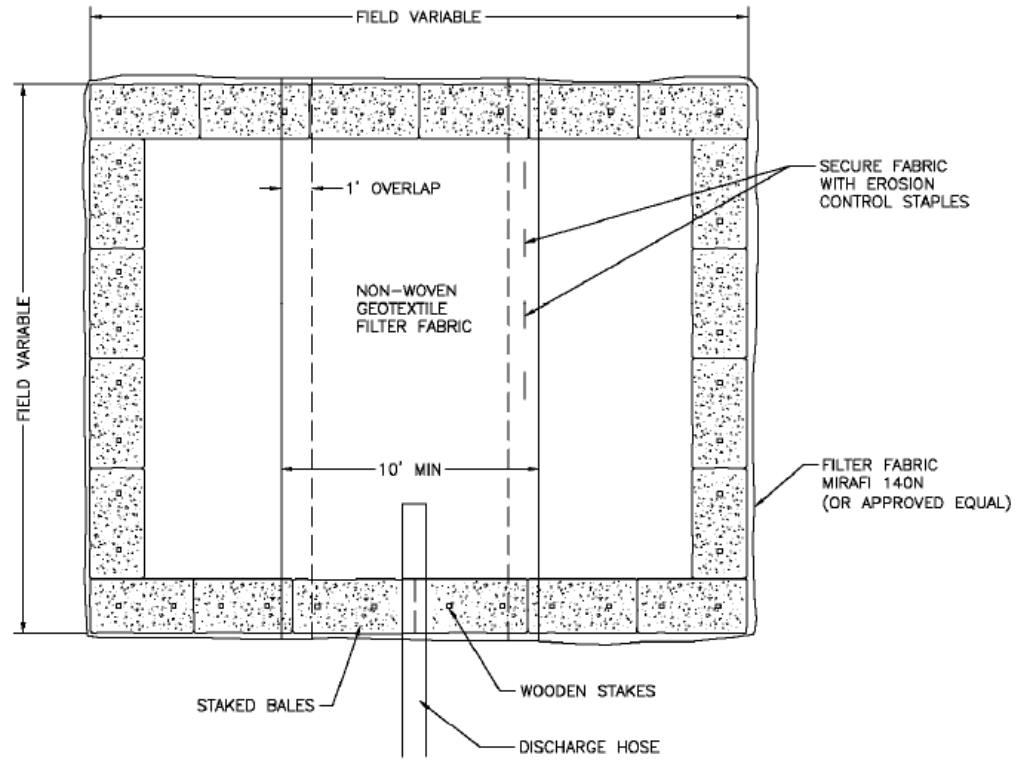

PLAN VIEW

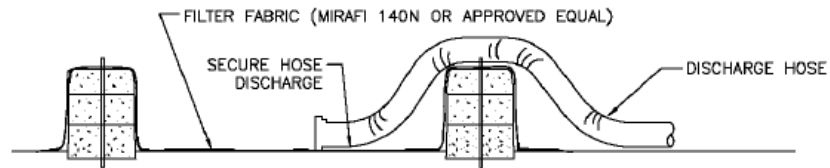

CROSS-SECTION

- NOTES:
1. NUMBER OF BALES MAY VARY DEPENDING ON SITE CONDITIONS.
 2. THE BASIN TO BE SIZED TO PREVENT DISCHARGE WATER FROM OVERTOPPING BASIN.
 3. KEEP AS FAR FROM WETLANDS AS PRACTICAL.
 4. CLEAN AND REMOVE AS SOON AS DEWATERING IS COMPLETE.

TYPICAL DEWATERING HAYBALE BASIN

LS-6831-0

APPENDIX A GLOSSARY

SANDY CRYSTAL TO REVIEW

Abandoned – The failure to maintain an existing structure in a condition for a period of five years, so that it is functional and intact (Wt 101.01). DES considers a man-made pond abandoned if wetlands vegetation has become dominant.

Aerobic – Living or active only in the presence of oxygen; a condition where oxygen is present.

Anaerobic – Living or active only in the absence of oxygen; a condition where oxygen is not present.

Bank – The transitional slope immediately adjacent to the edge of a surface water body, the upper limit of which is usually defined by a break in slope, or, for a wetland, where a line delineated in accordance with Env-Wt 301.01 indicates a change from wetland to upland. (Env-Wt 101.06).

Bog – A wetland distinguished by stunted evergreen trees and shrubs, peat deposits, poor drainage, and/or highly acidic soil and/or water conditions (Env-Wt 101.10).

Department – The N.H. Department of Environmental Services (Env-Wt 101.25).

Dewatering Basin – An established containment area for saturated materials. This measure is used for the purpose of de-watering soils for transport off site or for use in another location on site.

Detention/Retention Basin – A detention/retention basin is designed for the purpose of detaining or retaining water.

Dewatering – Use of a system of pumps, pipes and temporary holding dams to drain or divert waterways or wetlands before excavation of soils and sediments can occur.

Director – The director of the water division within the department (Env-Wt 101.28).

Dredge – To dig, excavate, or otherwise disturb the contour or integrity of sediments in the bank or bed of a wetland, a surface water body, or other area within the department's jurisdiction (Env-Wt 101.33).

Dredge Spoils – Material removed as the result of dredging (Env-Wt 101.34).

Embankment – A protective bank constructed of mounded earth or fill materials located between a roadway (or rail bed) and a seasonal stream or other wetland.

Emergent – A habitat wherein plants grow in standing water with the terminal parts above the water level.

Erosion Control – The utilization of methods to contain soil particles and to prevent them from being displaced or washed down slopes by rainfall or run-off and include, but are not limited to:

- (a) Seeding
- (b) Mulching
- (c) Using bales, silt fences, or impermeable material (Env-Wt 101.36)

Excavate/Excavation – To dig, remove, or form a cavity or a hole in an area within the department's jurisdiction (Env-Wt 101.37).

Fill (n.) – Any rock, soil, gravel, sand or other such material that has been deposited or caused to be deposited by human activity (Env-Wt 101.39).

Fill (v.) – To place or deposit materials in or on a wetland, surface water body, bank or otherwise in or on an area within the jurisdiction of the department (Env-Wt 101.40).

Flats – Relatively level landforms composed of unconsolidated mineral and organic sediments usually mud or sand, that are alternately flooded and exposed by the tides and that usually are continuous with the shore (Env-Wt 101.41).

Grade/Grading – The movement of soil and fill material to change the elevation of the land. The term refers to the combined actions of excavating and filling to change elevation or shape.

Grandfathered Status – That a structure (Env-Wt 101.44):

- a) Was in place before permit jurisdiction under RSA 482-A:3, I or its predecessor statute, RSA 483-A:1, I, took effect, which for areas in or adjacent to tidal waters means June 22, 1967 and for all other jurisdictional areas means July 2, 1969;
- b) Has remained unaltered in location, size and configuration; and
- c) Has not been abandoned.

Herbaceous – A plant with soft rather than woody tissues; typically the lowest vertical layer of vegetation in a natural community.

Hydric Soil – A soil that is saturated or flooded during a sufficient portion of the growing season to develop anaerobic conditions in the upper soil layers (Env-Wt 101.46).

Hydrology – The presence of recurrent, sustained inundation or saturation at or near the surface of the substrate sufficient to produce physical, chemical, and biological features reflective of anaerobic conditions.

Hydrophyte – A plant adapted for life in water, or saturated soils (Env-Wt 101.47).

Hydrophytic – A plant community tolerant of water, waterlogged soil or substrates that become inundated on a regular basis.

Intermittent Stream – A stream that flows for sufficient time to develop and maintain a defined channel, but which might not flow during dry portions of the year (Env-Wt 101.48).

In the Dry – Work done either during periods of low water or behind temporary diversions, such as Earth Dike / Drainage Swale and Lined Ditches (BMP #13) designed and installed in accordance with best management practices.

Jurisdiction – The regulatory authority under RSA 482-A (Env-Wt 101.50).

Lanceolate – In plants, spear-shaped leaves, gradually tapering toward the tip.

Legally Constructed Project – See “grandfathered status”.

Low Flow Conditions – Low water flow that generally occurs during the period from July 1 - September 30, as a result of decreased precipitation and the removal of water by increased evaporation and evapotranspiration by vegetation. Work done under low-flow conditions minimizes the potential for environmental damage.

Marsh – A wetland (Env-Wt 101.56):

- a) That is distinguished by the absence of trees and shrubs;
- b) Dominated by soft-stemmed herbaceous plants such as grasses, reeds, and sedges; and
- c) Where the water table is at or above the surface throughout the year, but can fluctuate seasonally.

Methods – Are the construction practices and procedures that take place through choosing the proper equipment, trucks and labor to execute the earth moving activities based on the existing conditions and implementing creative and sensitive scheduling for the daily activities.

Monocultures – Areas of vegetation composed of a single species.

Mottles – See “redoximorphic features”.

Mulch – A protective covering of various substances, especially organic, placed around plants to prevent evaporation of moisture and freezing of roots.

Natural Heritage Inventory – Information about rare, threatened and endangered species and exemplary natural communities in New Hampshire, which is maintained by the Natural Heritage Bureau of the NH Department of Resources and Economic Development.

Natural Woodland Buffer – A forested area consisting of various species of trees, saplings, shrubs, and ground covers in and combination and at any stage of growth (483-B: 4, XI).

Normal High Water Line – For lakes or ponds, the full lake elevation as determined by the director (Env-Wt 101.62).

Perennial – A stream that contains water at all times except during extreme drought.

Protected Shoreland – Natural, fresh water bodies without artificial impoundments, for artificially impounded fresh water bodies, and for coastal waters and rivers, and all land located within 250 feet of the reference line of public waters (483-B:4, XV).

Public Waters – Waterbodies that are subject to the Comprehensive Shoreland Protection Act (RSA 483-B) [Public](#) Waters shall include (483-B: 4, XVI):

- a) All lakes, ponds, and artificial impoundments greater than 10 acres in size;
- b) Coastal waters, being all waters subject to the ebb and flow of the tide, including the Great Bay Estuary and the associated tidal rivers; and
- c) Rivers, meaning all year round flowing waters of fourth order or higher and all rivers and river segments designated as protected under RSA 483:15.

Redoximorphic features – Colors in the soil that indicate water is seasonally present at the level the features are found.

Reference Line – means (483-B: 4, XVII):

- a) For all lakes, ponds, and artificial impoundments greater than 10 acres in size, the surface elevation as listed in the Consolidated List of Water Bodies subject to the Comprehensive Shoreland Protection Act as maintained by the department;
- b) For coastal water, the highest observable tide line, which means a line defining the furthest landward limit of tidal flow, not including storm events, which can be recognized by

indicators such as the presence of a strand line of flotsam and debris, the landward margin of salt-tolerant vegetation, or a physical barrier that blocks further flow of the tide.

Repair – The restoring of an existing legal structure by partial replacement of work, or broken, or unsound parts (Env-Wt 101.73).

Replacement – The substitution of a new structure for an existing legal structure with no change in size, dimensions, location, configuration, construction, or which conforms in all material aspects to the original structure (Env-Wt 101.74).

Rhizome – A horizontal, usually underground stem that often sends out roots.

River – A watercourse that is larger than a perennial stream and flows all year long.

Routine Utility Rights-of-Way (ROW) Maintenance Activity – Includes but is not limited to vegetation management and repair or replacement of existing utility structures.

Sand Dune – A hill or ridge of sand piled up by the wind and commonly found on the seacoast (482-A: 2, VII).

Scrub-shrub – Areas dominated by woody vegetation less than 20 feet tall. The vegetation includes true shrubs, young trees, and trees or shrubs that may be stunted because of environmental conditions. Wetlands scrub-shrub are flooded for extended periods during the growing season.

Sedimentation Controls – Silt fences, hay bales, and other methods utilized to trap water-borne sediment and provide protection against erosion until properly installed erosion controls can take effect (Env-Wt 101.83).

Shoreline Frontage – The average of the distances of the actual natural navigable shoreline footage and a straight line drawn between property lines, both of which are measured at the normal high water line. (Env-Wt 101.85)

Siltation Curtain – An impervious barrier erected to prevent silt and sand and/or fines from being washed into a wetland, surface water body or other area of concern (Env-Wt 101.87).

Surface Water Body or Surface Waters – Those portions of waters of the state, as defined by RSA 482-A: 4, which have standing or flowing water at or on the surface of the ground. This includes but is not limited to rivers, streams, lakes, ponds and tidal waters (Env-Wt 101.91).

Tidal Wetlands – A wetland whose vegetation, hydrology or soils are influenced by periodic inundation or tidal waters (Env-Wt 101.96).

Topsoil – The top layer of the earth's surface suitable for growth of plant life. Please note that topsoil is not readily available in every area of the earth's surface.

Turbidity – The condition in which solid particles suspended in water make the water cloudy or even opaque in extreme cases.

USGS (United States Geological Survey) topographic map – A map that uses contour lines to represent the three-dimensional features of a landscape on a two-dimensional surface. These maps use a line and symbol representation of natural and artificially created features in an area.

Map scale – 1:24,000 or 1:25,000. Maps are available at most outdoors and sporting goods stores, as well as bookstores. Digital versions of the USGS topographic maps are acceptable.

Vernal Pool – A surface water or wetland, including an area intentionally created for purposes of compensatory mitigation, which provides breeding habitat for amphibians and invertebrates that have adapted to the unique environment provided by such pools and which

- a) Is not the result of on-going anthropogenic activities that are not intended to provide compensatory mitigation, including but not limited to:
 - (1) Gravel pit operations in a pit that has been mined at least every other year; and
 - (2) Logging and agricultural operations conducted in accordance with all applicable New Hampshire statutes and rules; and
- b) Typically has the following characteristics:
 - (1) Cycles annually from flooded to dry conditions, although the hydroperiod, size, and shape of the pool might vary from year to year;
 - (2) Forms in a shallow depression or basin;
 - (3) Has no permanently flowing outlet;
 - (4) Holds water for at least 2 continuous months following spring ice-out;
 - (5) Lacks a viable fish population; and
 - (6) Supports one or more primary vernal pool indicators, or 3 or more secondary vernal pool indicators.

Wetland – An area that is inundated or saturated by surface or ground water at a frequency and duration sufficient to support, and that under normal conditions does support, a prevalence of vegetation (more than 50 percent) typically adapted for life in saturated soil conditions (hydric soils). Wetlands include but are not limited to swamps, marshes, bogs, and similar areas (Env-Wt 101.103).

APPENDIX B REFERENCES

Electric Power Research Institute (EPRI) Report Entitled: 2002, *Best Management Practices Manual For Access Road Crossings Of Wetlands And Waterbodies*,

NH Department of Agriculture Guide to Invasive Plants:
http://agriculture.nh.gov/divisions/plant_industry/documents/InvasivesBooklet2005.pdf

New Hampshire Department of Environmental Services:
<http://des.nh.gov/index.htm>

NHDES Emergency Wetland Impact Authorization Fact Sheet:
<http://des.nh.gov/organization/commissioner/pip/factsheets/wet/documents/wb-9.pdf>

NHDOT Best Management Practices for Roadside Invasive Plants:
<http://www.nh.gov/dot/org/projectdevelopment/environment/units/technicalservices/documents/BMPsforRoadsideInvasivePlants.pdf>

NHDOT Mowing Invasive Species Fact Sheet:
http://www.t2.unh.edu/pubs/fact_sheet_mowing.pdf

Rockingham County Conservation District, 1992, *Stormwater Management And Erosion And Sediment Control For Urban And Developing Areas In NH*.

UNH Forest Sustainability Standards Work Team, Society For The Protection Of New Hampshire Forests, 1997, *Good Forestry In The Granite State*

UNH Cooperative Extension, 1996, *Best Management Practices For Erosion Control On Timber Harvesting Operations In New Hampshire*.

USDA, NRCS. 2007. The PLANTS Database (<http://plants.usda.gov>, 4 June 2007). National Plant Data Center, Baton Rouge, LA 70874-4490 USA.

US Army Corp of Engineers: <http://www.usace.army.mil/>

USDA-NRCS PLANTS Database / Britton, N.L., and A. Brown. 1913. *Illustrated flora of the northern states and Canada*. Vol. 1: 11.
